

Safety Modules

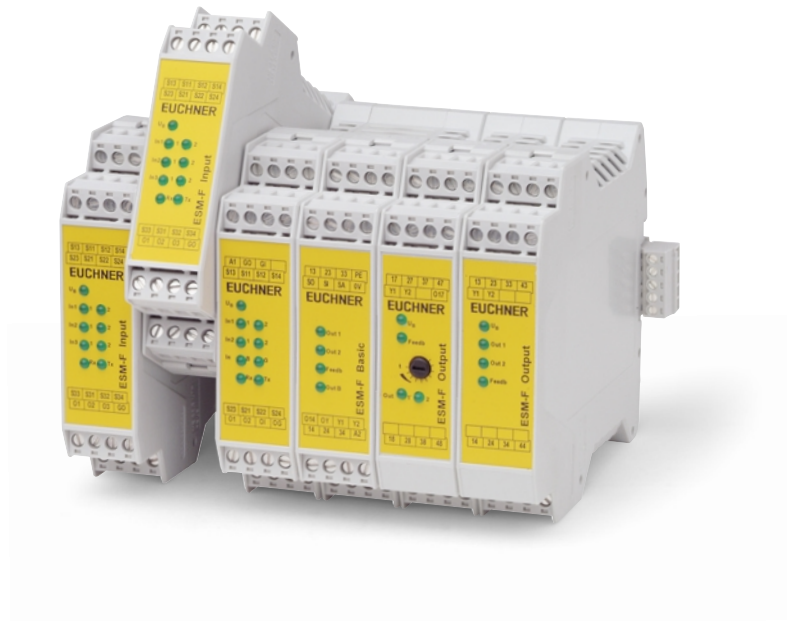

More than safety.



EUCHNER

More than safety.



Emil Euchner, the promoter of the enterprise and inventor of the multiple limit switch, around 1928

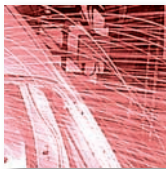

Around the world – the Swabian specialists for monitoring various motions in the field of machine and industrial manufacturing.

EUCHNER's history began in 1940 with the establishment of an engineering office by Emil Euchner. Since that time, EUCHNER has been involved in the design and development of switching devices for controlling a wide variety of motions in the field of machine and industrial manufacturing. 1953 Emil Euchner founded EUCHNER + Co., a milestone in the company's history. In 1952, he developed the first multiple limit switch – to this day a symbol of the enterprising spirit of this family-owned company.

Automation – Safety – ManMachine

Today, our products range from electromechanical and electronic components to complex system solutions. With this wide range of products we can provide the necessary technologies for offering the right solution for special requirements - regardless of whether these relate to reliable and precise positioning or to components and systems for safety engineering in the automation sector. EUCHNER products are sold through a world-wide sales network of competent partners. With our closeness to the customer and the guarantee of reliable solutions throughout the globe, we enjoy the confidence of customers all over the world.

Quality, reliability, precision

Quality, reliability and precision are the hallmarks of our corporate philosophy. Terms and values to which we feel totally committed. At EUCHNER, quality means that all our employees take personal responsibility for the company as a whole and in particular, for their own area of responsibility. Individual endeavour and carrying out tasks flawlessly result in products which are totally in line with the customers' needs and the requirements of the market. After all: Our customers and their needs are the focus of all our efforts. Through efficient and effective use of resources, the promotion of personal initiative, and courage in finding unusual solutions to the benefit of our customers, we ensure a high level of customer satisfaction. We familiarize ourselves with their needs, requirements and products and we learn from the experiences of our customers' customers.

EUCHNER – More than safety.



Quality – made by EUCHNER

Safety Modules ESM-F

General information

Plug-in and use! - The advantages of the modular system	4
Quick troubleshooting and fault rectification	4
Automatic or manual start	4
Contacts for higher currents and feedback loop	4
Setting up safety groups	4
Adding time-delay outputs	5

Safety relay base unit ESM-F-B...	6
--	----------

Safety relay input unit ESM-F-I...	8
---	----------

Safety relay output unit ESM-F-OS...	10
---	-----------

Safety relay output unit with time-delay ESM-F-OT...	12
---	-----------

General information

For machines and systems that can produce a risk for people when in operation, the EU Machinery directive defines minimum requirements that are intended to reduce to a minimum the specific hazards and the related risks of accident.

If all sources of danger cannot be eliminated by design measures, appropriate protective measures must be taken. Using safety guards, such as fences or similar, it is intended to prevent people entering the danger area. If users need to have access to the danger area during operation, movable safety guards such as protective doors, flaps, etc. are used. This is the case, for example, for loading or unloading, troubleshooting, machine setup or cleaning work.

To safeguard this access area, safety switches which have various principles of operation are used. These switches are designed to monitor the position of the safety guard and, when the safety guard is opened, to generate a signal which will safely interrupt the supply of power to the potentially hazardous parts of the system or which will ensure that the safety circuits are safely interrupted. The new EUCHNER safety modules series ESM-F ensure that the safety circuits are interrupted. On the one hand they safely evaluate switchgear connected such as

- ▶ mechanical safety switches with and without guard locking,
- ▶ non-contact safety switches,
- ▶ emergency stop switchgear,
- ▶ pressure sensitive mats, etc.

while on the other hand they safely shut down potentially hazardous machine functions.

The safety modules impress with their compact DIN rail housing and their suitability for applications up to safety category 4 in accordance with EN 954-1.

Plug-in and use! - The advantages of the modular system

Connecting several modules in series using the ESM-F system does not involve any wiring effort. The modules are connected together using a special connector system and are ready for use immediately. Programming is not necessary.

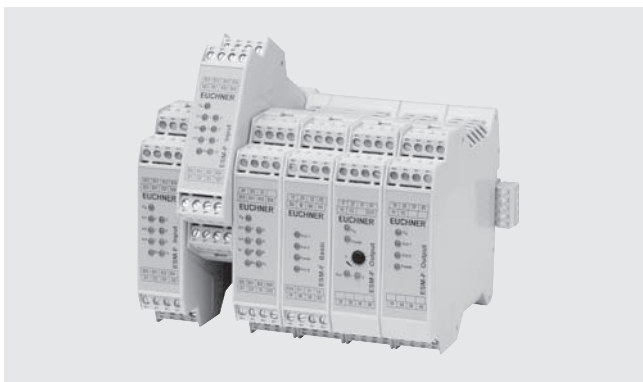

To be able to work with the system, it is first necessary to connect a base unit. The input units are connected to the left of the base unit and the output units to the right. In this way it is easy to expand the system. By simply connecting together the modules, it is possible to implement any combination of non-time-delay and time-delay safety contacts. The number of expansion modules is unlimited.

The uniform and compact design of all the devices in the entire series is particularly suitable for installation in compact control cabinets.

Quick troubleshooting and fault rectification

Every ESM-F module is equipped with LEDs that indicate the device status and the state of the inputs and outputs. For simpler evaluation, this information can also be sent to the control system using a communication module.

The safety devices are connected using plug-in connection terminals that can be quickly removed from the device making it possible to rapidly replace a faulty module. The faulty module is simply removed and replaced with a new module - that's it! Function is restored immediately.

Automatic or manual start

The base unit can be started either manually using a Start button or automatically.

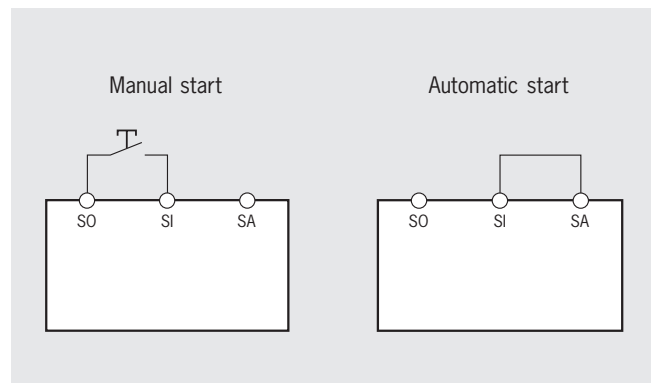

Contacts for higher currents and feedback loop

To be able to use contacts that are suitable for higher currents, the safety contacts on the device can be extended using external contactors with positively driven contacts.

The coils on the contactors are operated using the safety contacts on the base unit or on an output unit; the monitoring contacts on the contactor are monitored by the feedback loop inputs on the ESM-F module.

Setting up safety groups

Safety groups can be formed using the ESM-F. In this way it is possible to shutdown only that part of the system in which maintenance or setup work is to be performed. All remaining parts of the system continue to function.

A dedicated base unit is used for each group. In this way each group can be evaluated separately. By simply connecting the module groups in a specific manner, it can be achieved that certain safety components only act on one base unit, while other safety components, e. g. emergency stop buttons, act on the entire system.

The logical allocation is realized using a single cable. The group output on a higher-level input unit is fed to a base unit in a different group.

The higher-level input unit then acts on this group.

The example given shows the correct allocation of the modules and the connection of the connection cable:

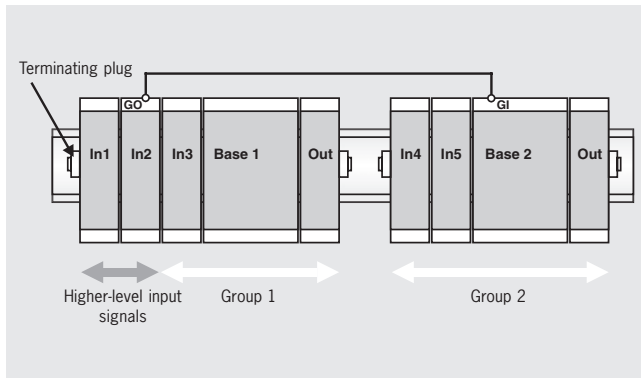

The input units 1 and 2 shutdown the output units in both groups, input unit 3 only acts on group 1 and the units 4 and 5 only on group 2. The connection cable is connected between the GO terminal on the **last** input unit **on the right** (here: In2), which is to act on all groups, and the GI terminal on the base unit in group 2 (base 2). Using the ESM-F system it is also possible to form more than two groups. A wide range of combinations of input units can be allocated to each group. If required, we will be pleased to send you further information.

Adding time-delay outputs

Sometimes it is necessary to continue to supply parts of the system with power after an emergency stop request, e. g. to move tools to a safe home position or to brake parts of the system that run on. In this case a off delayed unit is used on the right beside the standard output units. This additional module switches off its four safety contacts at latest after the time-delay set on the potentiometer has elapsed (controlled stop, stop category 1 in accordance with EN 60204-1).

A special advantage is the ease with which time-delay outputs can be added: if more than four time-delay contacts are required, it is possible to fit further standard output units to the right of the off delayed output unit; these additional standard output units are then switched at the same time as the off delayed unit.

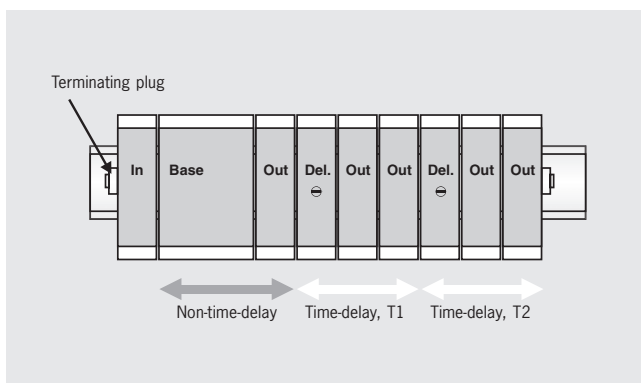

If several different time-delays are required, the system can be expanded with further off delayed output units.

Safety relay base unit ESM-F-B..

- ▶ Safety category 4 in acc. with EN 954-1
- ▶ Can be expanded with input and output units as required
- ▶ Plug-in mounting on DIN rail bus system
- ▶ Redundancy and cyclical monitoring



Dimension drawing

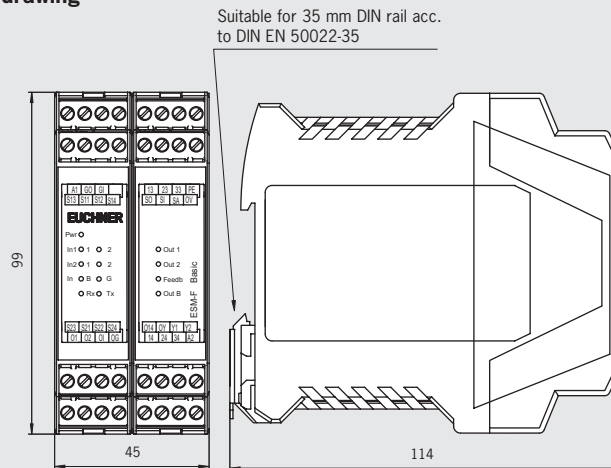

Function

The ESM-F-B forms the central control unit in the overall system or a logical group, if a system is divided into several segments with different safety-related functions.

The ESM-F-BSN... is suitable for the connection of normally closed contacts, the ESM-F-BMN... for the connection of safety switches with normally closed/normally open contacts, e. g. CMS safety switches.

Both have:

- ▶ Monitored start button or auto start
- ▶ Feedback loop
- ▶ 2 inputs (each 2-channel with short circuit and earth fault monitoring)
- ▶ 3 normally open safety contacts (each redundant and fault monitored)
- ▶ 6 semiconductor outputs
- ▶ LED indicators for device status as well as the state of the inputs and outputs
- ▶ Input for forming groups (see section *Setting up safety groups*, page 4)

Monitoring outputs

The *On* state of the related monitoring contact corresponds to the following signals:

- ▶ O1, O2: inputs 1 and 2 on the base unit closed
- ▶ OI: all input units on the left in the *On* state
- ▶ OG: group signal is present
- ▶ OY: feedback loop closed
- ▶ O14: safety contacts on the base unit closed, starting command for output units

Block diagram

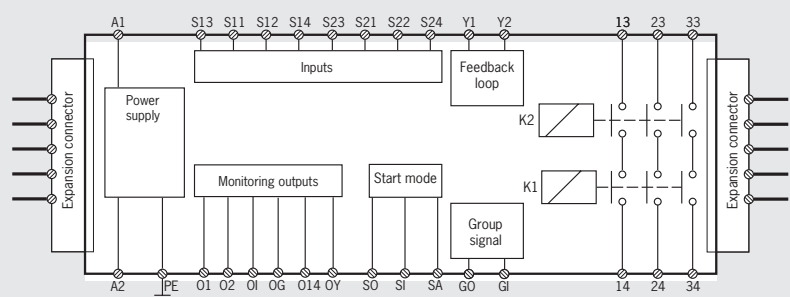

Outputs

Safety contacts

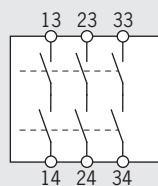

Monitoring outputs

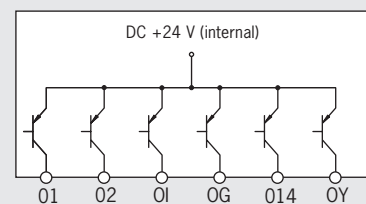

Ordering table

Item	Version	Order No.
ESM-F-BSN-2CO2	Base unit, standard	095 120
ESM-F-BMN-2CO2	Base unit, for non-contact safety switches	095 919

Technical Data

Parameters	Value			Unit
	min.	typ.	max.	
Housing material	plastic PA6.6			
Dimensions	114 x 99 x 45			mm
Weight	0.26			kg
Ambient temperature	-15	-	+ 55	°C
Degree of protection according to IEC/EN 60529	IP 20			
Degree of contamination	2			
Mounting	TBUS plug on 35 mm DIN rail acc. to DIN EN 50022-35			
Type of connection	plug-in connection terminals			
Terminals	0.14	-	2.5	mm ²
Operating voltage U_B	24 ± 10% ¹⁾			DC V
Rated supply frequency	50	-	60	Hz
Power consumption	approx. 3.5			VA
Current consumption (without monitoring outputs)	-	-	140	mA
Control voltage for start button (S11)	18.6	24	26	DC V
Control cable length (with cross-section 0.75 mm ²)	-	-	1000	m
Control current for start button	approx. 50			mA
Safety contacts	3 NO contacts (redundant)			
- Continuous current I_N per current path	-	-	8	A
- Cumulative current of all contacts	-	-	15	A
- Switching voltage AC	-	-	250	AC V
- Switching voltage DC	-	-	24	DC V
- Breaking capacity AC	-	-	2,000	VA
- Breaking capacity DC (in utilization category DC-13)	-	-	72	W
- Switching current at 24 V	20	-	-	mA
- Utilization category according to EN 60 947-5-1	AC-15 3A 250V / DC-13 3A 24V AC-12 8A 250V / DC-12 8A 50V			
Monitoring output short circuit proof	6 semiconductor outputs			
- Semiconductor output current	-	-	30	mA
- Semiconductor output voltage	-	24	-	DC V
Inputs	ESMF-BSN-2C02	2 inputs, NC contact/NC contact, 2-channel with short circuit and earth fault monitoring		
	ESMF-BMN-2C02	2 inputs, NO contact/NC contact, 2-channel with short circuit and earth fault monitoring		
Contact fuses (control circuit fuse)	T 6 / F 8			A
Contact material	AgSnO ₂			
Mechanical life	1 x 10 ⁷ operating cycles			
Electrical life	1 x 10 ⁵ operating cycles			
Reverse polarity protection	yes			
Rated impulse withstand voltage U_{imp}	2.5			kV
Leakage path/air gap acc. to DIN VDE 0110-1:1997-04	4			kV
In compliance with	EN 60204-1:1998 / EN 954-1: 1996			
LEDs	13 status indicators (green)			

1) With external supply voltage $U_B = DC 24 V$, an insulating transformer in accordance with IEC/EN 61558-2-6 must be connected before the device.

Circuit

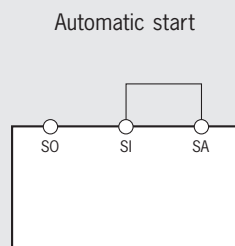
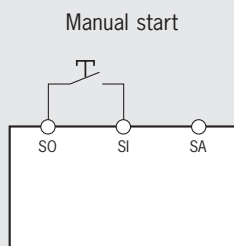

Outputs and feedback loop

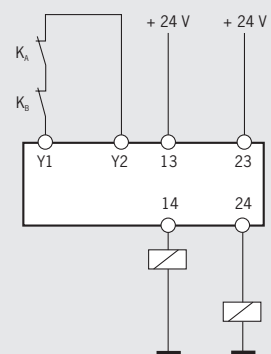

ESMF-BSN-2C02

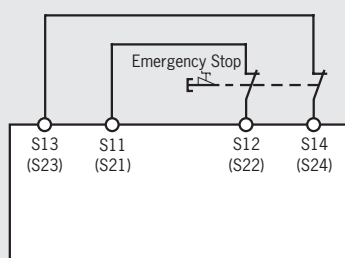

EMERGENCY STOP 2-channel

ESMF-BMN-2C02

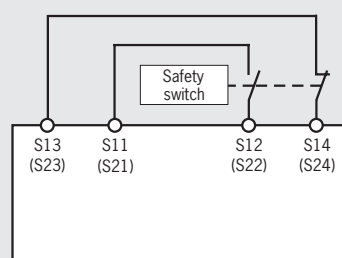

Safety switch 2-channel

Group formation

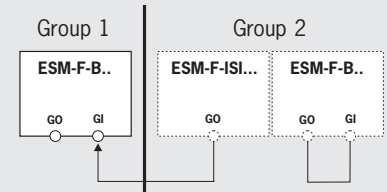

Safety relay input unit ESM-F-I...

- ▶ Safety category 4 in acc. with EN 954-1
- ▶ Plug-in mounting on DIN rail bus system
- ▶ Redundancy and cyclical monitoring
- ▶ With three 2-channel or six 1-channel inputs
- ▶ Connection of non-contact safety switches



Dimension drawing

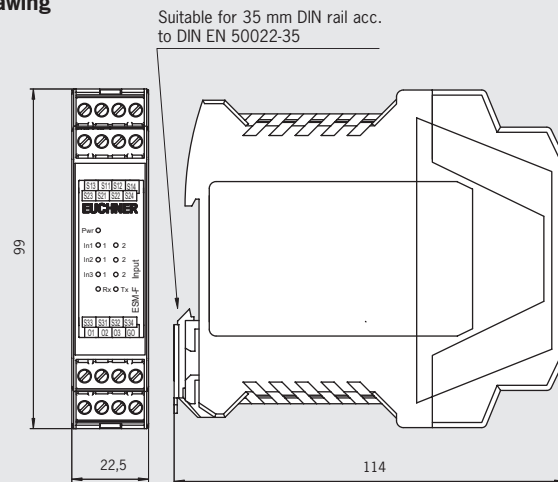

Function

Safety components with normally closed contacts such as safety switches, emergency stop buttons, etc. can be connected to the input units ESM-F-ISI.... The version ESM-F-IMI... is suitable for the connection of safety switches with normally closed/normally open contacts, e. g. CMS safety switches.

The input units detect the switch state of each safety component connected and signal this information to the base unit.

They have:

- ▶ Six 1-channel or three 2-channel inputs with short circuit and earth fault monitoring
- ▶ 3 semiconductor outputs
- ▶ LED indicators for device status as well as the state of the inputs and outputs
- ▶ Output for forming groups (see section *Setting up safety groups*, page 4)

Monitoring outputs

The On state of the related monitoring contact corresponds to the following signals:

- ▶ 01, 02, 03: safety switch 1, 2 or 3 closed

Block diagram

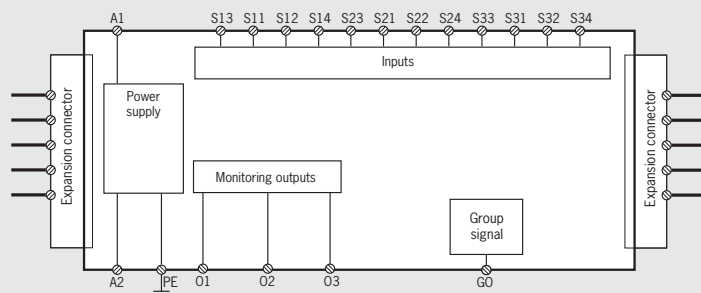

Outputs

Monitoring outputs

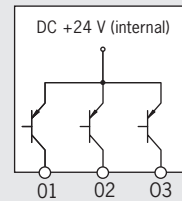

Ordering table

Item	Version	Order No.
ESM-F-ISI-3C2	Input unit, standard; 3 inputs, 2-channel	095 122
ESM-F-ISI-6C1	Input unit, standard; 6 inputs, 1-channel	095 123
ESM-F-IMI-3C2	Input unit for non-contact safety switches; 3 inputs, 2-channel	095 124

Technical Data

Parameters	Value			Unit
	min.	typ.	max.	
Housing material	plastic PA6.6			
Dimensions	114 x 99 x 22.5			mm
Weight	0.13			kg
Ambient temperature	-15	-	+ 55	°C
Degree of protection according to IEC/EN 60529	IP 20			
Mounting	TBUS plug on 35 mm DIN rail acc. to DIN EN 50022-35			
Type of connection	plug-in connection terminals			
Terminals	0.14	-	2.5	mm ²
Operating voltage U _B	24 ± 10% ¹⁾			DC V
Power consumption	approx. 4.2			VA
Current consumption without monitoring outputs	-	80	-	mA
Current consumption with 3 monitoring outputs	-	-	170	mA
Monitoring output short circuit proof	3 semiconductor outputs			
- Semiconductor output current	-	-	30	mA
- Semiconductor output voltage	-	24	-	DC V
Inputs	ESM-F-ISI-3C2	3 inputs, NC contact/NC contact, 2-channel with short circuit and earth fault monitoring		
	ESM-F-ISI-6C1	6 inputs, NC contact, 1-channel with short circuit and earth fault monitoring		
	ESM-F-IMI-3C2	3 inputs, NC contact/NO contact, 2-channel with short circuit and earth fault monitoring		
Reverse polarity protection	yes			
In compliance with	EN 60204-1:1998 / EN 954-1: 1996			
LEDs	9 status indicators (green)			

1) Connection using TBUS plug connector

Circuit

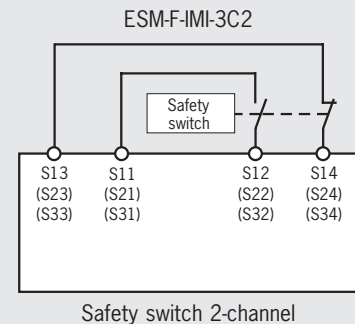
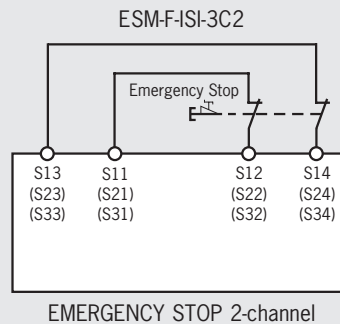
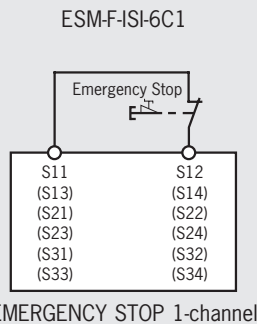

Group formation ESM-F-I...

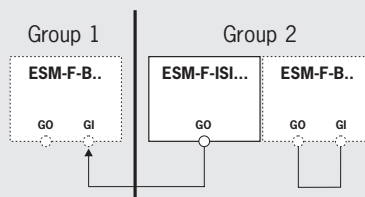

Safety relay output unit ESM-F-OS...

- ▶ Safety category 4 in acc. with EN 954-1
- ▶ Plug-in mounting on DIN rail bus system
- ▶ Redundancy and cyclical monitoring



Dimension drawing

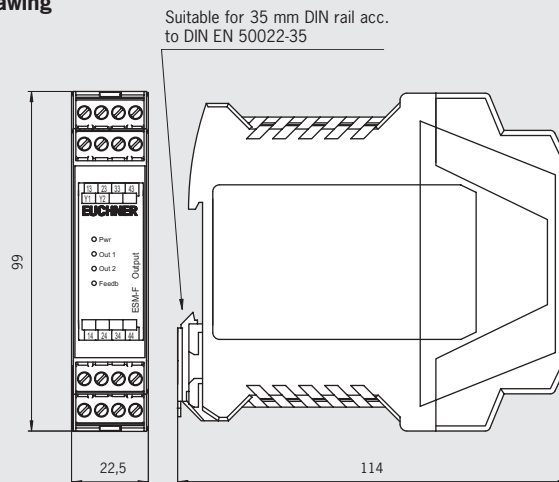

Function

The output units ESM-F-O... are operated via the base unit. The output units can be used to directly switch power components such as contactors, motors, etc.

Depending on the version they have:

- ▶ Four normally open contacts (each redundant and fault monitored)
- ▶ LED indicators for device status as well as the state of the inputs and outputs
- ▶ Feedback loop for contacts connected after the outputs

Block diagram

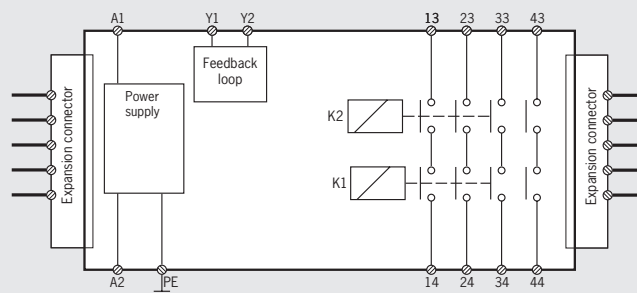

Outputs

Safety contacts

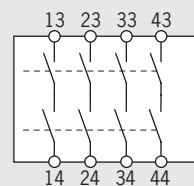

Ordering table

Item	Version	Order No.
ESM-F-OSN-04	Output unit, standard; 4 safety contacts	095 125

Technical Data

Parameters	Value			Unit
	min.	typ.	max.	
Housing material	plastic PA6.6			
Dimensions	114 x 99 x 22.5			mm
Weight	0.18			kg
Ambient temperature	-15	-	+ 55	°C
Degree of protection according to IEC/EN 60529	IP 20			
Degree of contamination	2			
Mounting	TBUS plug on 35 mm DIN rail acc. to DIN EN 50022-35			
Type of connection	plug-in connection terminals			
Terminals	0.14	-	2.5	mm ²
Operating voltage U _e	24 ± 10% ¹⁾			AC/DC V
Rated supply frequency	50	-	60	Hz
Power consumption	approx. 2.4			VA
Current consumption	-	-	100	mA
Safety contacts	4 NO contacts (redundant)			
- Continuous current I _N per current path	-	-	8	A
- Cumulative current of all contacts	-	-	15	A
- Switching voltage AC	-	-	250	AC V
- Switching voltage DC	-	-	50	DC V
- Breaking capacity AC	-	-	2,000	VA
- Breaking capacity DC (in utilization category DC-13)	-	-	72	W
- Switching current at 24 V	20	-	-	mA
- Utilization category according to EN 60 947-5-1	AC-15 3A 250V / DC-13 3A 24V AC-12 8A 250V / DC-12 8A 50V			
Contact fuses (control circuit fuse)	T 6 / F 8			A
Contact material	AgSnO ₂			
Mechanical life	1 x 10 ⁷ operating cycles			
Electrical life	1 x 10 ⁵ operating cycles			
Reverse polarity protection	yes			
Rated impulse withstand voltage U _{imp}	2.5			kV
Leakage path/air gap acc. to DIN VDE 0110-1:1997-04	4			kV
In compliance with	EN 60204-1:1998 / EN 954-1: 1996			
LEDs	4 status indicators (green)			

1) Connection using TBUS plug connector

Circuit

Outputs and feedback loop

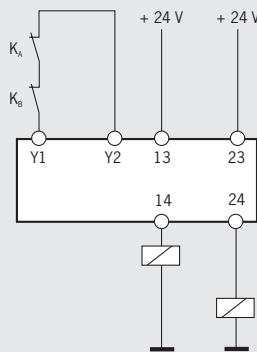

Safety relay output unit with time-delay ESM-F-OT...

- ▶ Safety category 4 in acc. with EN 954-1
- ▶ Plug-in mounting on DIN rail bus system
- ▶ Redundancy and cyclical monitoring
- ▶ Time-delay fixed or adjustable



Dimension drawing

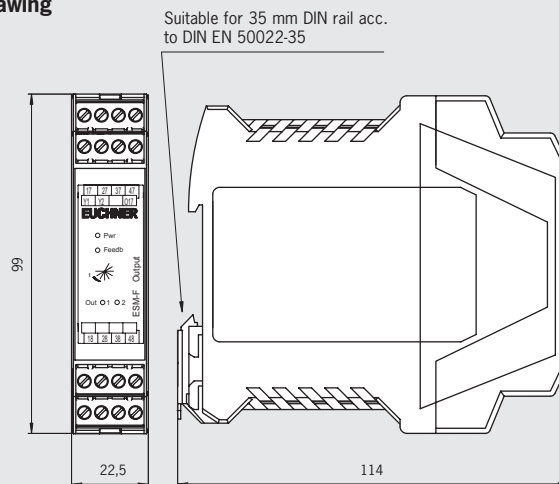

Function

The output units ESM-F-OT... are operated via the base unit. The output units can be used to switch power components such as contactors, motors, etc. with a time-delay.

Depending on the version they have:

- ▶ Four normally open contacts (each redundant and fault monitored) with adjustable or fixed time-delay
- ▶ LED indicators for device status as well as the state of the inputs and outputs
- ▶ Feedback loop for contacts connected after the outputs

Block diagram

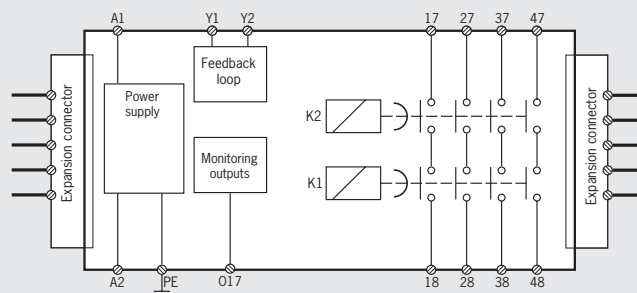

Monitoring outputs

The On state of the related monitoring contact corresponds to the following signal:

- ▶ O17: switch state of the safety contacts

Outputs

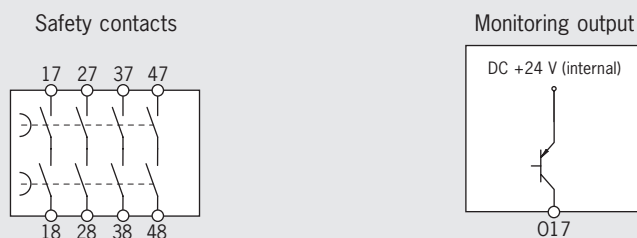

Ordering table

Item	Version	Order No.
ESM-F-OTN-04	Output unit, adjustable time-delay; 4 safety contacts	095 126
ESM-F-OT05N-04	Output unit, fixed time-delay 0.5 s; 4 safety contacts	095 917

Technical Data

Parameters	Value			Unit
	min.	typ.	max.	
Housing material	plastic PA6.6			
Dimensions	114 x 99 x 22.5			mm
Weight	0.18			kg
Ambient temperature	-15	-	+ 55	°C
Degree of protection according to IEC/EN 60529	IP 20			
Degree of contamination	2			
Mounting	TBUS plug on 35 mm DIN rail acc. to DIN EN 50022-35			
Type of connection	plug-in connection terminals			
Terminals	0.14	-	2.5	mm ²
Operating voltage U _a	24 ± 10% ¹⁾			DC V
Rated supply frequency	50	-	60	Hz
Power consumption	approx. 2.4			VA
Current consumption (without monitoring outputs)	-	-	100	mA
Safety contacts	4 NO contacts (redundant)			
- Continuous current I _N per current path	-	-	8	A
- Cumulative current of all contacts	-	-	15	A
- Switching voltage AC	-	-	250	AC V
- Switching voltage DC	-	-	50	DC V
- Breaking capacity AC	-	-	2,000	VA
- Breaking capacity DC (in utilization category DC-13)	-	-	72	W
- Switching current at 24 V	20	-	-	mA
- Utilization category according to EN 60 947-5-1	AC-15 3A 250V / DC-13 3A 24V AC-12 8A 250V / DC-12 8A 50V			
Time-delay	ESM-F-OTN-04	adjustable: 1 ... 30		s
	ESM-F-OT05N-04	0.5		s
Monitoring output short circuit proof	1 semiconductor output			
- Semiconductor output current	-	-	30	mA
- Semiconductor output voltage	-	24	-	DC V
Contact fuses (control circuit fuse)	T 6 / F 8			A
Contact material	AgSnO ₂			
Mechanical life	1 x 10 ⁷ operating cycles			
Electrical life	1 x 10 ⁵ operating cycles			
Reverse polarity protection	yes			
Rated impulse withstand voltage U _{imp}	2.5			kV
Leakage path/air gap acc. to DIN VDE 0110-1:1997-04	4			kV
In compliance with	EN 60204-1:1998 / EN 954-1: 1996			
LEDs	4 status indicators (green)			

1) Connection using TBUS plug connector

Circuit

Outputs and feedback loop

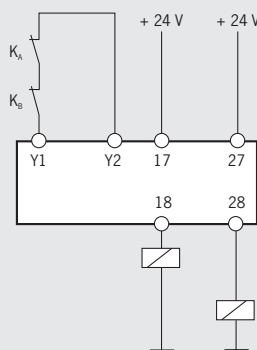

Representation international

Australia

Micromax Pty. Ltd.
PO Box 1238
AUS-Wollongong
NSW Australia 2500
Tel. +61 (0) 2 4271 1300
Fax +61 (0) 2 4271 8091
micromax@micromax.com.au

Austria

EUCHNER Ges. mbH
Süddruckgasse 4
A-2512 Tribuswinkel
Tel. +43 (0) 22 52 4 21 91
Fax +43 (0) 22 52 4 52 25
info@euchner.at

Benelux

EUCHNER (BENELUX) B.V.
Postbus 119
NL-3350 AC Papendrecht
Tel. +31 (0) 78 6 15 47 66
Fax +31 (0) 78 6 15 43 11
info@euchner.nl

Brazil

EUCHNER Itda.
Av. Prof. Luiz Ignacio Anhaia
Mello no. 4387
S. Lucas
São Paulo SP Brasil
CEP 03295-000
Tel. +55 (0) 11 69 18-22 00
Fax +55 (0) 11 61 01-06 13
euchner@euchner.com.br

Canada

IAC & Associates Inc.
1925 Provincial Road
Windsor, Ontario N9A 6J3
Tel. +1 (5 19) 966-3444
Fax +1 (5 19) 966-6160
sales@iacnassociates.com

China

EUCHNER Electric Shanghai Ltd.
No. 8 Workshop, Hi-Tech Zone
N. 503 MeilengDa Road
Songjiang Industrial Zone
Shanghai
Tel. +86 (0) 21 5774 7090
+86 (0) 21 5774 7091
Fax +86 (0) 21 5774 7599
info@euchner.com.cn

Knowhow I&C Co.

C-2204 Webok Times Center
No. 17 Zhongguancun Nandajie
Beijing, 100081
Tel. +86 10 8857 8899
Fax +86 10 8857 8989
info@knowhow.cn

Czech Republic

Amtek spol s.r.o.
Videňská 125
CZ-619 00 Brno
Česká republika
Tel. +420 5 47 12 55 70
Fax +420 5 47 12 55 56
amtek@amtek.cz

Denmark

Robotek EL & TEKNIK A/S
Blokken 31, Postboks 30
DK-3460 Birkerød
Tel. +45 44 84 73 60
Fax +45 44 84 41 77
info@robotek.dk

Eastern Europe

Hera Handels Ges. mbH
Hauptstraße 61
A-2391 Kaltleitgeben
Tel. +43 (0) 22 38 7 75 18
Fax +43 (0) 22 38 7 75 28
hera@telering.at

Finland

Sähkölehto Oy
Lehto & Co.
Holkkitie 14
FIN-00880 Helsinki
Tel. +358 (0) 9 774 6420
Fax +358 (0) 9 759 1071
office@sahkolehto.fi

France

EUCHNER France S.A.R.L.
Immeuble Le Colorado
ERAGNY PARC
Rue Rosa Luxembourg
Parc d'affaires des Bellevues
F-95610 ERAGNY sur OISE
Tel. +33 (0) 1 39 09 90 90
Fax +33 (0) 1 39 09 90 99
info@euchner.fr

Hong Kong

Imperial Engineers &
Equipment Co. Ltd.
Unit B 12th Floor
Cheung Lee Industrial Building
9 Cheung Lee Street
HK-Chaiwan, Hong Kong
Tel. +8 52/28 89 02 92
Fax +8 52/28 89 18 14
ieechk@netvigator.com

Hungary

EUCHNER Ges.mBH
Magyarországi Fióktelep
H-2045 Törökbálint
Tópark Ipari park 3301/28
Feketerét u. 1.
Tel. +36/23/428 374
Fax +36/23/428 375
info@euchner.hu

India

Teknic Controlgear PVT Ltd.
703, Madhava,
Bandra Kurla Complex
Bandra East
IND-Mumbai 400051
Tel. +91-22 2659 2392
+91-22 2659 2394
Fax +91-22 2659 2391
teknic@vsnl.com

Iran

INFOCELL IRAN Co.
84, Manoucheri Ave.,
P.O. Box 81655-861, Isfahan, IRAN
Tel. +98 311 221 1358
Fax +98 311 222 6176
info@infocell-co.com

Italy

TRITECNICA S.r.l.
Viale Lazio 26
I-20135 Milano
Tel. +39 02 54 194-1
Fax +39 02 55 01 04 74
info@tritecnica.it

Japan

Solton Co. Ltd.
2-13-7, Shin-Yokohama
Kohoku-ku, Yokohama
Japan 222-0033
Tel. +81 (0) 45 4 71 77 11
Fax +81 (0) 45 4 71 77 17
sales@solton.co.jp

Korea

EUCHNER Korea Ltd.
RM 810 Daerung Technotown
#448 Gasan-Dong
Kumchon-Gu, Seoul
Tel. +82 (02) 2107 3500
Fax +82 (02) 2107 3999
sijang@euchner.co.kr

Mexico

SEPIA S.A. de C.V.
Maricopa # 10
302, Col. Napoles.
Del. Benito Juarez
MEX-03810 Mexico D:F:
Tel. +52 (5) 6822 347
Fax +52 (5) 5367 787
sepia@prodigy.net.mx

New Zealand

WAF, W. Arthur Fisher
11 Te Apunga Place
Mt. Wellington
Auckland, New Zealand
Tel. +64 (0) 9 270 0100
Fax +64 (0) 9 270 0900
chrisl@waf.co.nz

Norway

ELIS ELEKTRO AS
Jericoveien
N-1067 Oslo
Tel. +47 (22) 90 56 70
Fax +47 (22) 90 56 71
post@eliselektro.no

Poland

ELTRON
pl. Wolności 7 B
PL 50-071 Wrocław
Tel. +48 (0)71 343 97 55
Fax +48 (0)71 343 96 64
LP@eltron.pl

Portugal

PAM – Serviços Técnicos
Industriais, Lda
Rua Senhora da Alegria 188
P-4785 Alvarelhos STS
Tel. +3 51 (0) 22 98 27 518
Fax +3 51 (0) 22 98 27 519
pam@mail.telepac.pt

Singapore

SENTRONICS
Automation and Marketing Pte Ltd
Blk 3021 Ubi Avenue 2
03-169
SGP-Singapore 408897
Tel. +65/6744 8018
Fax +65/6744 1929
sentronics@pacific.net.sg

Slovenia

SMM d.o.o.
Production Systems Ltd.
Jaskova 18
SLO-2001 Maribor
Slovenia
Tel. +386 (0)2 450 23 26
Fax +386 (0)2 462 51 60
franc.kit@smm.si

Spain

EUCHNER, S.L.
Gurutegi 12 - Local 1
Polígono Belartza
E-20018 San Sebastián
Tel. +34 (9 43) 31 67 60
Fax +34 (9 43) 31 64 05
euchner@edunet.es

Sweden

Censit AB
Box 331
S-33123 Värnamo
Tel. +46 (0) 3 70 69 10 10
Fax +46 (0) 3 70 188 88
info@censit.se

Switzerland

EUCHNER AG
Ing- und Vertriebsbüro
Großstraße 17
CH-8887 Mels/St. Gallen
Tel. +41 (0) 81 7 20 45 90
Fax +41 (0) 81 7 20 45 99
euchner.schweiz@bluewin.ch

Taiwan

Daybreak International
(Taiwan) Corp.
3 Fl., 124 Chung-Cheng Road
Shihlin
Taipei, Taiwan
Tel. +8 86 (0) 2 8 866 1231
Fax +8 86 (0) 2 8 866 1239
day111@ms23.hinet.net

Turkey

PINAR MÜHENDISLIK SAN.
ve Tic. Ltd. Sti.
Perpa Tic. Merkezi
Kat. 11, No. 1705
TR-80270 Okmeydanı/Istanbul
Tel. +90 (0) 2 12 2 20 02 77
Fax +90 (0) 2 12 2 20 13 16
pinarmuh@superonline.com

United Kingdom

EUCHNER (U.K.) Ltd.
Unit 2, Petre Drive,
GB-Sheffield, S4 7PZ
Tel. +44 (0) 1 14 2 56 01 23
Fax +44 (0) 1 14 2 42 53 33
info@euchner.co.uk

USA

EUCHNER USA Inc.
6723 Lyons St.
USA-E. Syracuse, NY 13057
Tel. +1 (3 15) 7 01-03 15
Fax +1 (3 15) 7 01-03 19
info@euchner-usa.com

More than safety.

EUCHNER GmbH + Co. KG
Kohlhammerstraße 16
D-70771 Leinfelden-Echterdingen
Germany

Tel. +49/711/75 97-0
Fax +49/711/75 33 16
www.euchner.com
info@euchner.de



EUCHNER