

Safety Relays



ESM. ■



More than safety.



EUCHNER

More than safety.



Emil Euchner, the company's founder and inventor of the multiple limit switch, circa 1928.

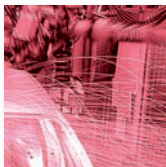

Around the world – the Swabian specialists in motion sequence control for mechanical and systems engineering.

EUCHNER's history began in 1940 with the establishment of an engineering office by Emil Euchner. Since that time, EUCHNER has been involved in the design and development of switchgear for controlling a wide variety of motion sequences in mechanical and systems engineering. In 1953, Emil Euchner founded EUCHNER + Co., a milestone in the company's history. In 1952, he developed the first multiple limit switch – to this day a symbol of the enterprising spirit of this family-owned company.

Automation – Safety – ManMachine

Today, our products range from electromechanical and electronic components to complex system solutions. With this wide range of products we can provide the necessary technologies to offer the right solution for special requirements – regardless of whether these relate to reliable and precise positioning or to components and systems for safety engineering in the automation sector.

EUCHNER products are sold through a world-wide sales network of competent partners. With our closeness to the customer and the guarantee of reliable solutions throughout the globe, we enjoy the confidence of customers all over the world.

Quality, reliability, precision

Quality, reliability and precision are the hallmarks of our corporate philosophy. They represent concepts and values to which we feel totally committed.

At EUCHNER, quality means that all our employees take personal responsibility for the company as a whole and, in particular, for their own field of work. This individual commitment to perfection results in products which are ideally tailored to the customers' needs and the requirements of the market. After all: our customers and their needs are the focus of all our efforts. Through efficient and effective use of resources, the promotion of personal initiative and courage in finding unusual solutions to the benefit of our customers, we ensure a high level of customer satisfaction. We familiarize ourselves with their needs, requirements and products and we learn from the experiences of our customers' own customers.

EUCHNER – More than safety.



Quality – made by EUCHNER

Safety Relays ESM

General Information		4
Advantages		5
Application examples		6
Article selection table		7
Safety Relays		
ESM-BL2..	Safety relay to safety category 3 2 positively driven safety contacts	8
ESM-BA2..	Safety relay to safety category 4 2 positively driven safety contacts	10
ESM-BA3..	Safety relay to safety category 4 3 positively driven safety contacts 1 door auxiliary contact	12
Safety 2-hand control relay		
ESM-2H2..	Safety 2-hand control relay to safety category 4 / IIIC 2 positively driven safety contacts	14
Expansion modules		
ESM-ES3..	Safety expansion 3 positively driven safety contacts	16
ESM-TE3..	Safety time relay expansion 3 time-delay, positively driven safety contacts	18

Appendix

Index		20
-------	--	----

General Information

For machines and equipment which make dangerous movements and which could injure persons in the vicinity, the EC machinery directive defines minimum specifications which reduce individual hazards and the associated risk of accidents to a minimum. If all sources of danger cannot be ruled out by constructive measures, appropriate safeguards must be provided.

In practice, movable safety guards are used for these applications. They are important particularly where access to the danger zone is required.

For example when loading or unloading, trouble-shooting, machine setting and cleaning.

In order to provide suitable protection for such access areas, safety switches which have various function principles are used. These are designed to monitor the position of the moveable part of the safety guard and to generate a signal when the safety guard is opened which will dependably break the electric circuit or will ensure that the electric circuit is dependably broken.

The new series ESM safety relays are designed to dependably break the electric circuit.

On the one hand they reliably evaluate connected switchgear such as

- ▶ mechanical safety switches with and without a guard locking device,
- ▶ non-contact safety switches,
- ▶ E-STOP switchgear,
- ▶ pressure sensitive mats etc.

while on the other they dependably switch off hazardous machine functions.

The safety relays' internal switching system is designed to ensure that not only will the machine always be switched off in the event of internal machine defects, but that it cannot be restarted under any circumstances.

Safety relays have a variety of uses

- ▶ to protect people, machinery and manufacturing processes,
- ▶ to evaluate various types of switchgear and safety guards,
- ▶ to interrupt the energy supply in accordance with stop category 0 or 1 in accordance with EN 60204-1

which can be simply adapted to suit the required application.

The compact standard mounting housing (22.5 mm wide) with DIN rail mounting and the application options up to control category 4 in accordance with EN 954-1 make a compelling argument for the use of these safety relays.

By simply linking the modules, it is possible to implement most combinations of non-time-delay and time-delay safety contacts. The uniform and compact design of the units make them particularly suitable for control cabinets which also frequently come in a compact configuration. Its simple construction means that the function and integration of the individual units is uncomplicated this enables fault detection in the case of machinery breakdowns.

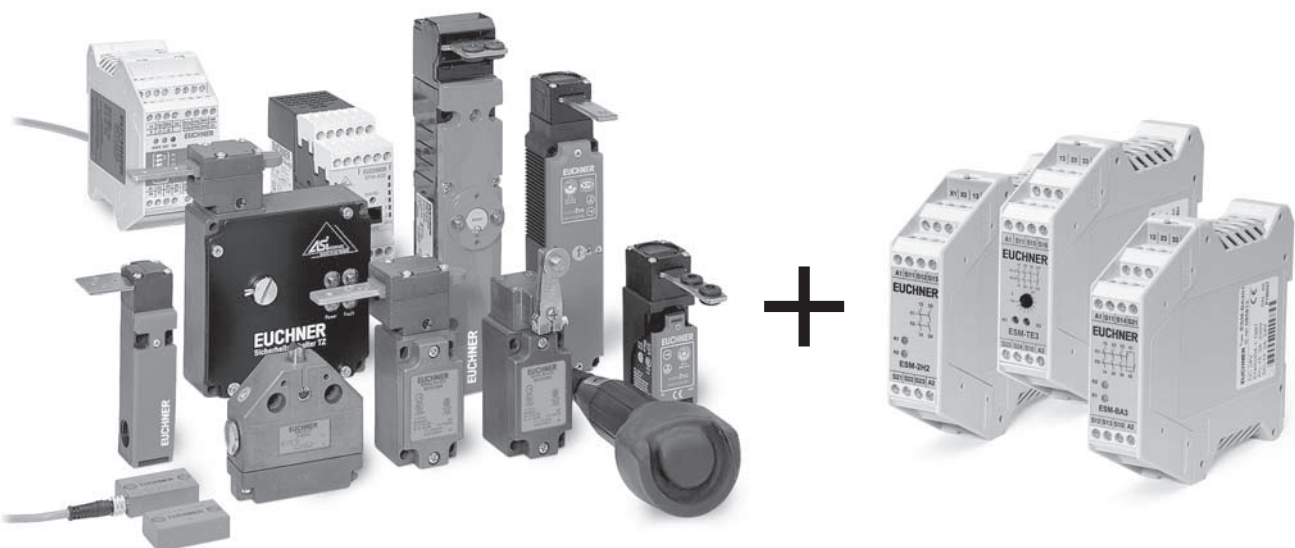

Your Advantages

Safety relays are used to evaluate signals generated by safety switches, e-stop switches, 2-hand controls etc. and for subsequent reliable stoppage of hazardous machine functions.

- ▶ Compact size
- ▶ Uniform design
- ▶ Many combination and expansion options so that most applications can be catered for with just a few different safety relays and modules.
 - ▶ low storage costs
- ▶ Variety of relay types with up to 3 safety contacts and one NC auxiliary contact
- ▶ Can be used up to safety category 4 and for stop category 0 or 1
- ▶ 1 and 2 channel versions available
- ▶ Various voltage ranges can be supplied
- ▶ Time-delay (continuously adjustable up to 30 s) and non-time-delay expansion modules can be supplied to match the basic units
- ▶ 2-hand control module available in standard housing (22.5 mm wide) with DIN rail mounting
- ▶ Automatic and manual start (monitoring available as an option)
- ▶ Earth fault and short circuit monitoring of the input channels

Application examples

Manual start: Safety relay ESM-BA3..
used in conjunction with EUCHNER safety switch TZ...

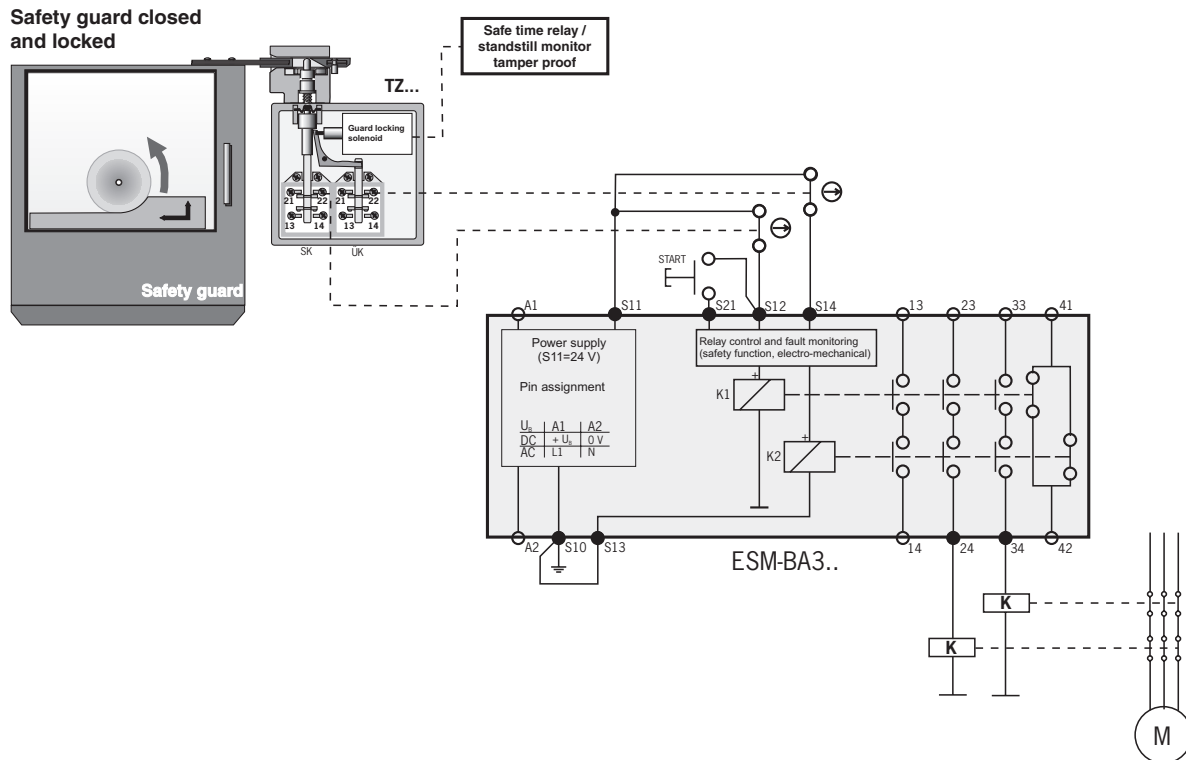

Manual start: Safety relay ESM-BA3.. and expansion module ESM-TE3..
used in conjunction with EUCHNER safety switch NZHS...

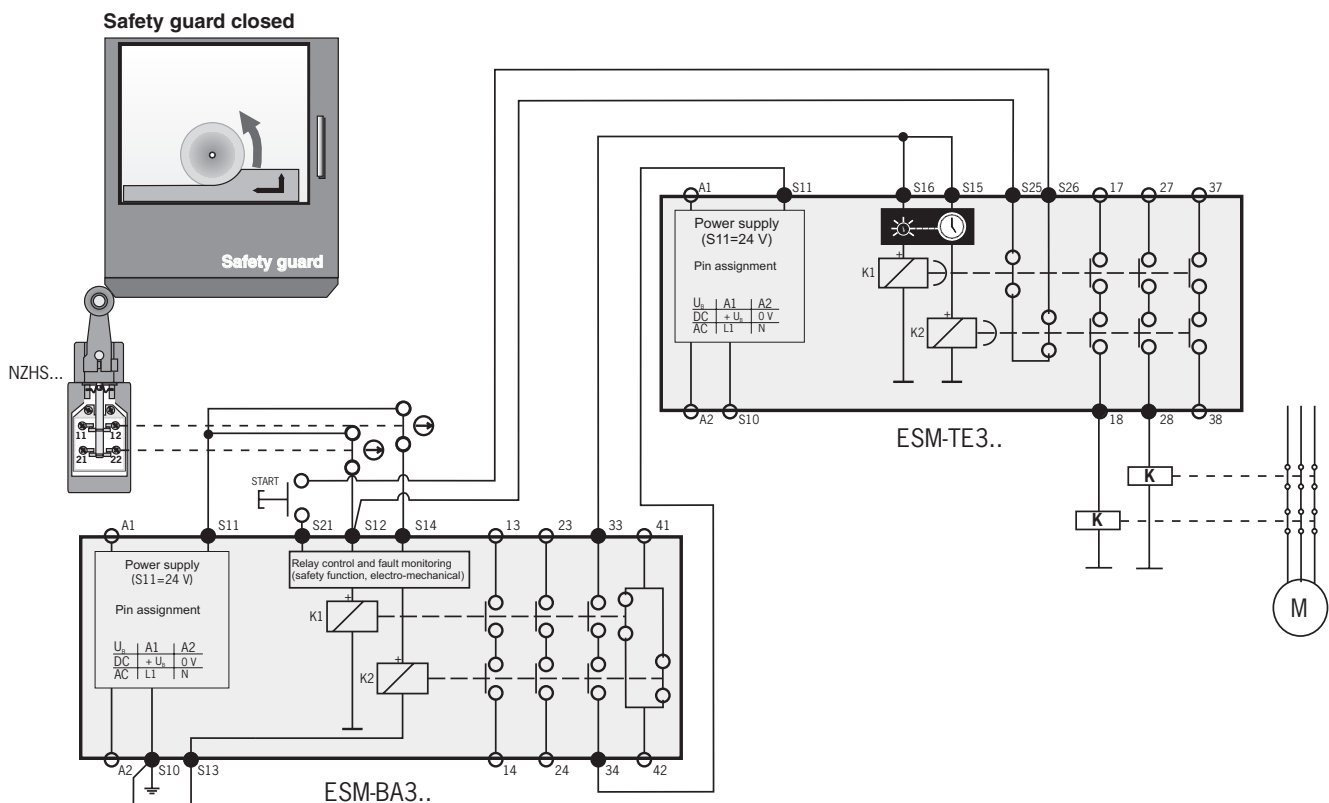

Article selection table

The following table can be used to select the particular EUCHNER ESM safety relay required for your application:

Unit version	Operating voltage	Number of safety contacts	Safety category	Monitored start	Automatic/manual start	Earth fault monitoring	Short-circuit monitoring	Time delay contacts	Door auxiliary contacts	Switching voltage AC max.	Switching current AC max.	Article	Order No.	Page
Basic relay	AC/DC 24 V	2	3	-	x	-	-	-	-	250	6	ESM-BL201	085 607	8
	AC/DC 24 V	2	4	x	x	x	x	-	-	250	6	ESM-BA201	085 610	10
	AC/DC 24 V	3	4	x	x	x	x	-	1	250	8	ESM-BA301	085 613	12
	AC 115 V	2	3	-	x	-	-	-	-	250	6	ESM-BL202	085 608	8
	AC 115 V	2	4	x	x	x	x	-	-	250	6	ESM-BA202	085 611	10
	AC 115 V	3	4	x	x	x	x	-	1	250	8	ESM-BA302	087 412	12
	AC 230 V	2	3	-	x	-	-	-	-	250	6	ESM-BL203	085 609	8
	AC 230 V	2	4	x	x	x	x	-	-	250	6	ESM-BA203	085 612	10
	AC 230 V	3	4	x	x	x	x	-	1	250	8	ESM-BA303	087 413	12
2-hand control relay	AC/DC 24 V	2	4 III C	x	x	x	x	-	-	250	6	ESM-2H201	085 620	14
Expansions	AC/DC 24 V	3	1)	x	x	x	-	-	1	250	6	ESM-ES301	085 614	16
	AC/DC 24 V	3		x	x	x	-	3	1	250	6	ESM-TE301	085 617	18
	AC 115 V	3		x	x	x	-	-	1	250	6	ESM-ES302	085 615	16
	AC 115 V	3		x	x	x	-	3	1	250	6	ESM-TE302	085 618	18
	AC 230 V	3		x	x	x	-	-	1	250	6	ESM-ES303	085 616	16
	AC 230 V	3		x	x	x	-	3	1	250	6	ESM-TE303	085 619	18

1) Dependent on the category of the basic relay

Safety relay ESM-BL2..



- ▶ STOP category 0
- ▶ Safety category 3
- ▶ 2 positively driven safety contacts with redundancy and cyclical monitoring of the internal components
- ▶ Single-channel or dual-channel control without detection of shorts across input contacts
- ▶ Complies with EN 60 204-1 and EN 954-1

Dimension drawing

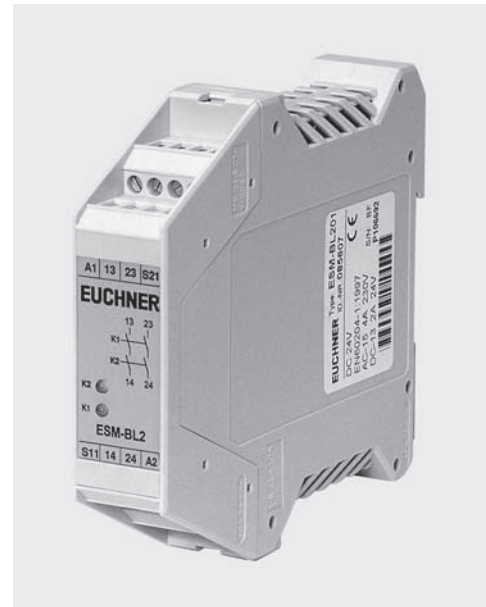
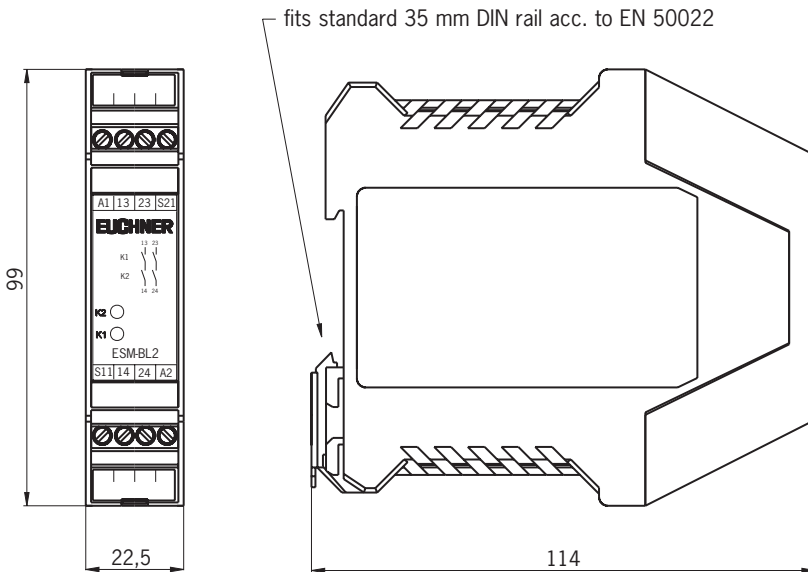

Block diagram

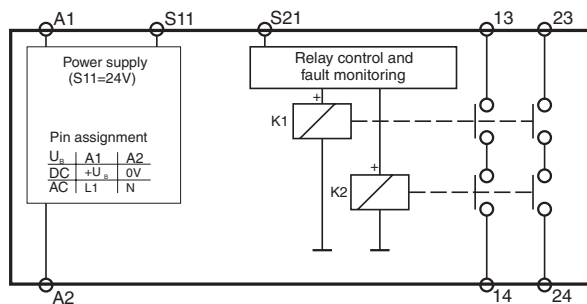

Pin assignment

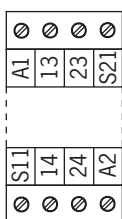

- A1 ▶ Power supply $+U_B / L$
- A2 ▶ Power supply $-U_B / N$
- S11 ▶ 24 V DC
- S21 ▶ Start input
- 13 ▶ Safety contact 1.1
- 14 ▶ Safety contact 1.2
- 23 ▶ Safety contact 2.1
- 24 ▶ Safety contact 2.2

Output contacts, positively driven

- ▶ 2 safety contacts (NO contact)

Connection options

- ▶ Single or dual-channel E-STOP
- ▶ Single or dual-channel safety guard

Assembly instructions

- ▶ The safety relay must be installed in a suitable enclosure (control cabinet, protective housing - to at least IP54).
- ▶ The relay is fitted by clipping it to a standard 35 mm DIN rail in accordance with EN 50022.

Instructions for electrical connection

- ▶ All electrical inputs must be isolated from the mains by an isolating transformer (in accordance with IEC/EN 61558-2-6) or by a similar isolating method.

Safety considerations

- ▶ The relay has a redundant switching design with automatic control. This means that the safety system is still effective even in the event of a component failure.
- ▶ Errors in the supply cable to the safety relay are not detected.

Technical data

Parameters	Value			Unit	
	min.	typ.	max.		
Housing material	Plastic PA6.6				
Dimensions	114 x 99 x 22.5			mm	
Weight	0.23			kg	
Ambient temperature	at $U_B = AC/DC 24 V$	- 15	-	+ 60	°C
	at $U_B = AC 115/230 V$	- 15	-	+ 40	
Degree of protection according to IEC/EN 60 529	IP 20				
Mounting	35 mm DIN rail according to DIN EN 50022-35				
Type of connection	Screw terminals				
Terminals	0.14	-	2.5	mm ²	
Operating voltage U_B	ESM-BL201	24 ± 10% (via isolating transformer in according to IEC/EN 61558-2-6)		AC/DC V	
	ESM-BL202	115 ± 10%		AC V	
	ESM-BL203	230 ± 10%		AC V	
Rated supply frequency	50	-	60	Hz	
Power consumption	approx. 4			VA	
Control voltage for start button (S11)	18.6	24	26	DC V	
Control cable length (with cross-section 0.75 mm ²)	-	-	1000	m	
Control current for start button (S11)	approx. 40			mA	
Safety contacts	2 NO contacts				
- Continuous current I_N per current path	-	-	6	A	
- Cumulative current of all contacts	-	-	12	A	
- Switching voltage AC	-	-	250	AC V	
- Switching voltage DC	-	-	24	DC V	
- Breaking capacity AC	-	-	1,500	VA	
- Breaking capacity DC (in utilization category DC-13)	-	-	30	W	
- Switching current at 24 V	20	-	-	mA	
- Utilization category according to IEC/EN 60947-5-1	AC-15 4A 230V / DC-13 2A 24V AC-12 6A 250V / DC-12 1.25A 24V				
- Breaking capacity in acc. with UL	6A 250AC V / 2A 24 DC V per contact				
Contact fuses (control circuit fuse)	T 4 / F 6			A	
Contact material	AgNi-10				
Mechanical life	1 x 10 ⁷ operating cycles				
Electrical life	1 x 10 ⁵ operating cycles				
Reverse polarity protection	at version $U_B = 24 DC V$				
Rated impulse withstand voltage U_{imp}	2.5			kV	
Leakage path/air gap acc. to DIN VDE 0110-1:1997-04	4			kV	
In compliance with	EN 60 204-1: 1998 / EN 954-1: 1996				
LEDs	2, status displays for relays K1 and K2				

Application examples

Dual-channel safety guard connection

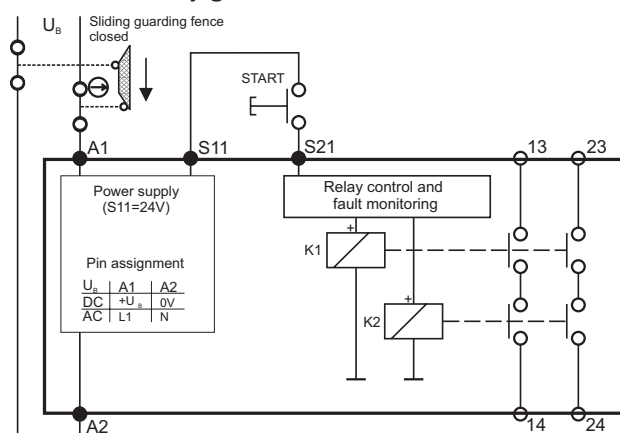

Single-channel Emergency STOP connection

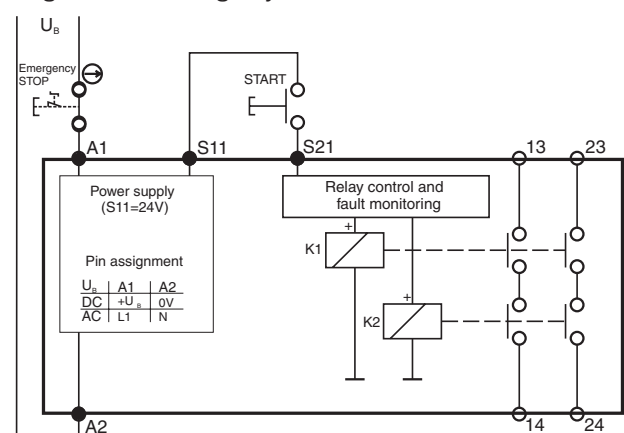

Ordering table

Article	Operating voltage	Safety contacts	Order No.
ESM-BL201	AC/DC 24 V ± 10%	2 NO contacts (redundant)	085 607
ESM-BL202	AC 115 V ± 10%	2 NO contacts (redundant)	085 608
ESM-BL203	AC 230 V ± 10%	2 NO contacts (redundant)	085 609

Safety relay ESM-BA2..



- ▶ STOP category 0
- ▶ Safety category 4
- ▶ 2 positively driven safety contacts with redundancy and cyclical monitoring of the internal components
- ▶ Single-channel or dual-channel control
- ▶ Short-circuit and/or earth fault monitoring
- ▶ Complies with EN 60 204-1 and EN 954-1

Dimension drawing

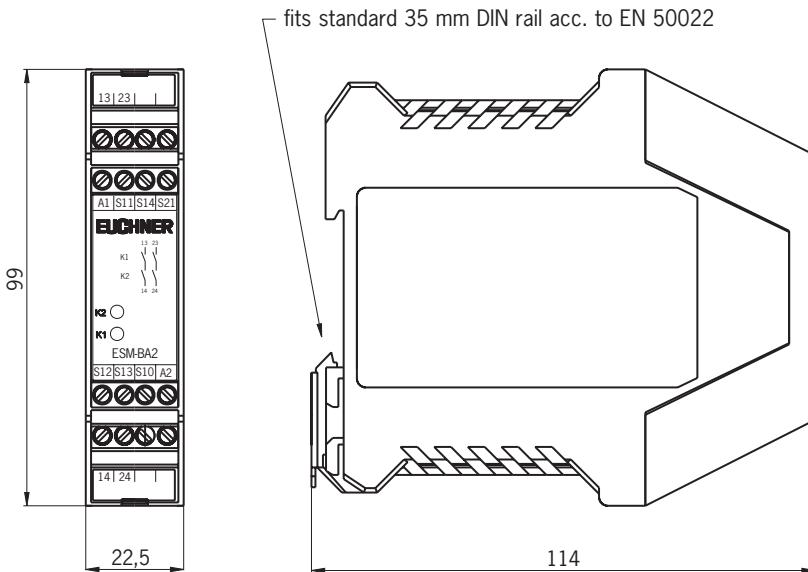

Block diagram

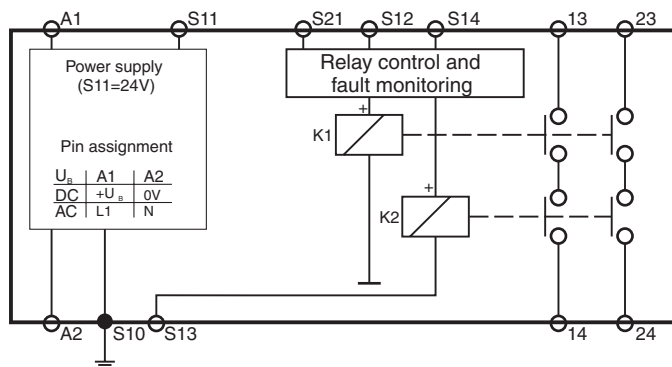

Pin assignment

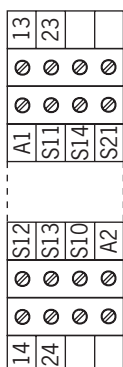

- A1 ▶ Power supply $+U_B / L$
- A2 ▶ Power supply $-U_B / N$
- S10 ▶ GND
- S11 ▶ 24 V DC
- S12 ▶ Input 1.1
- S13 ▶ Input 2.1
- S14 ▶ Input 2.2
- S21 ▶ Start input
- 13 ▶ Safety contact 1.1
- 14 ▶ Safety contact 1.2
- 23 ▶ Safety contact 2.1
- 24 ▶ Safety contact 2.2

Output contacts, positively driven

- ▶ 2 safety contacts (NO contact)

Connection options

- ▶ Single or dual-channel E-STOP
- ▶ Single or dual-channel safety guard

Assembly instructions

- ▶ The basic safety relay must be installed in a suitable operating enclosure (control cabinet, protective housing - at least IP54).
- ▶ The basic relay is installed by clipping it to a standard 35 mm DIN rail in accordance with EN 50022.

Instructions for electrical connection

- ▶ All electrical inputs must be isolated from the mains by an isolating transformer (in accordance with IEC/EN 61558-2-6) or by a similar isolating method.

Safety considerations

- ▶ The basic relay has a redundant switching design with automatic control. This means that the safety system is still effective even if the component fails.
- ▶ Short-circuits and earth faults in the supply cable to the safety relay are detected.

Technical data

Parameters	Value			Unit
	min.	typ.	max.	
Housing material	Plastic PA6.6			
Dimensions	114 x 99 x 22.5			mm
Weight	0.23			kg
Ambient temperature	at $U_B = AC/DC24 V$	- 15	+ 60	°C
	at $U_B = AC 115/230 V$	- 15	+ 40	
Degree of protection according to IEC/EN 60 529	IP 20			
Mounting	35 mm DIN rail according to DIN EN 50022-35			
Type of connection	Screw terminals			
Terminals	0.14	-	2.5	mm ²
Operating voltage U_B	ESM-BA201	24 ± 10% (via isolating transformer in according to IEC/EN 61558-2-6)		AC/DC V
	ESM-BA202	115 ± 10%		AC V
	ESM-BA203	230 ± 10%		
Rated supply frequency	50	-	60	Hz
Power consumption	approx. 4			VA
Control voltage for start button (S11)	18.6	24	26	DC V
Control cable length (with cross-section 0.75 mm ²)	-	-	1000	m
Control current for start button (S11)	approx. 40			mA
Safety contacts	2 NO contacts			
- Continuous current I_N per current path	-	-	6	A
- Cumulative current of all contacts	-	-	12	A
- Switching voltage AC	-	-	250	AC V
- Switching voltage DC	-	-	24	DC V
- Breaking capacity AC	-	-	1,500	VA
- Breaking capacity DC (in utilization category DC-13)	-	-	30	W
- Switching current at 24 V	20	-	-	mA
- Utilization category according to IEC/EN 60947-5-1	AC-15 4A 230V / DC-13 2A 24V AC-12 6A 250V / DC-12 1.25A 24V			
- Breaking capacity in acc. with UL	6A 250AC V / 2A 24 DC V per contact			
Contact fuses (control circuit fuse)	T 4 / F 6			A
Contact material	AgNi-10			
Mechanical life	1 x 10 ⁷ operating cycles			
Electrical life	1 x 10 ⁵ operating cycles			
Reverse polarity protection	at version $U_B = 24 DC V$			
Rated impulse withstand voltage U_{imp}	2.5			kV
Leakage path/air gap acc. to DIN VDE 0110-1:1997-04	4			kV
In compliance with	EN 60 204-1: 1998 / EN 954-1: 1996			
LEDs	2, status displays for relays K1 and K2			

Application examples

Dual-channel safety guard connection

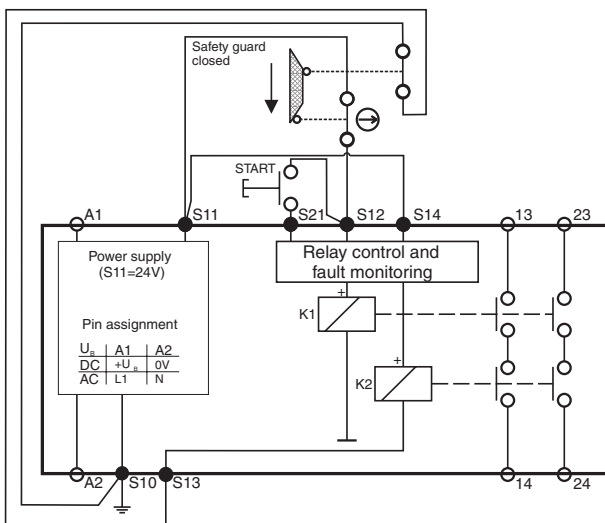

Dual-channel Emergency STOP connection

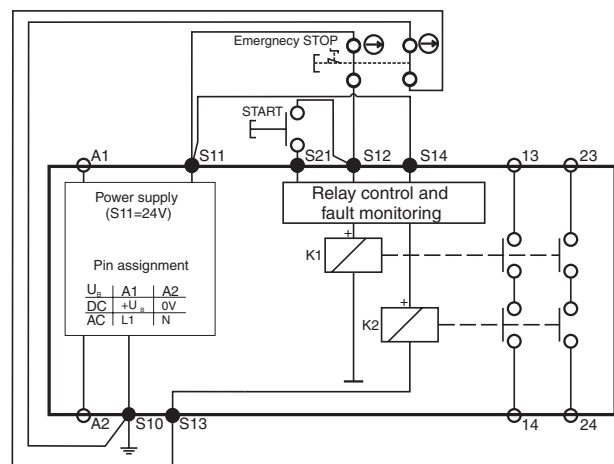

Ordering table

Article	Operating voltage	Safety contacts	Order No.
ESM-BA201	AC/DC 24 V ± 10%	2 NO contacts (redundant)	085 610
ESM-BA202	AC 115 V ± 10%	2 NO contacts (redundant)	085 611
ESM-BA203	AC 230 V ± 10%	2 NO contacts (redundant)	085 612

Safety relay ESM-BA3..



- ▶ STOP category 0
- ▶ Safety category 4
- ▶ 3 positively driven safety contacts with redundancy and cyclical monitoring of the internal components
- ▶ Single-channel or dual-channel control
- ▶ Short-circuit and/or earth fault monitoring
- ▶ Complies with EN 60 204-1 and EN 954-1

Dimension drawing

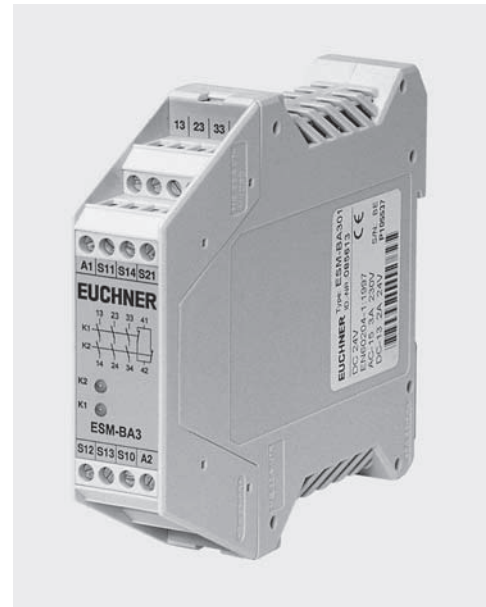
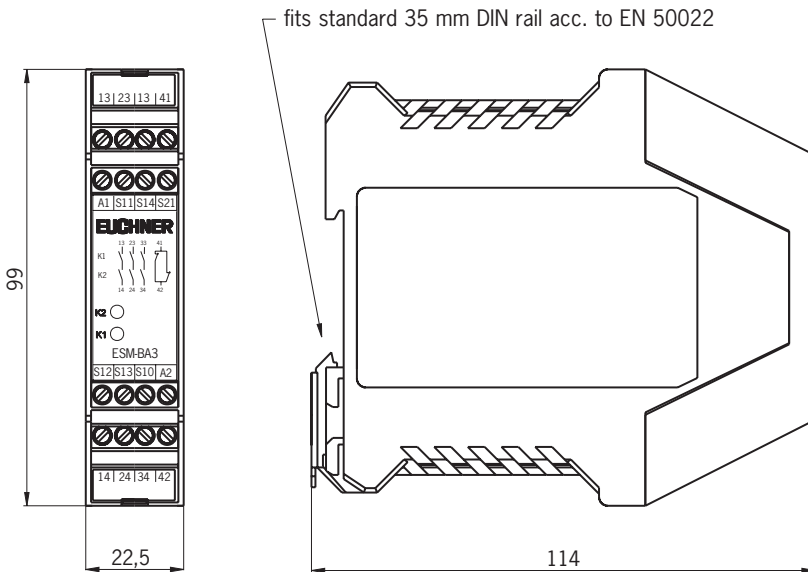

Output contacts, positively driven

- ▶ 3 safety contacts (NO contact)
- ▶ 1 door auxiliary contact (NC contact)

- ▶ Single or dual-channel E-STOP
- ▶ Single or dual-channel safety guard

- ▶ The basic safety relay must be installed in a suitable operating enclosure (control cabinet, protective housing - at least IP54).
- ▶ The basic unit is installed by clipping it to a standard 35 mm DIN rail in accordance with EN 50022.

- ▶ All electrical inputs must be isolated from the mains by an isolating transformer (in accordance with IEC/EN 61558-2-6) or by a similar isolating method.

- ▶ The basic relay has a redundant switching design with automatic control. This means that the safety system is still effective even if the component fails.
- ▶ Short-circuits and earth faults in the supply cable to the safety unit are detected.

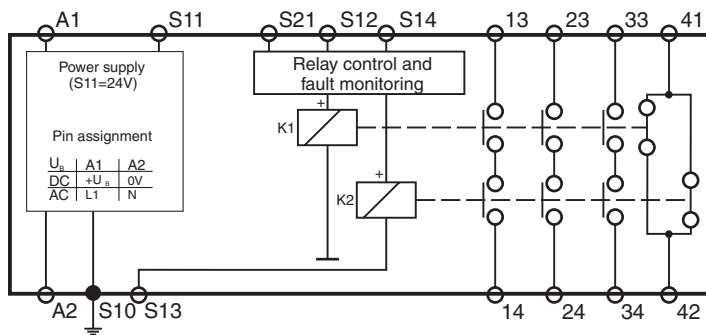

13	23	33	41
14	24	34	42
A1	S11	S14	S21
S12	S13	S10	A2

- A1 ▶ Power supply $+U_B / L$
- A2 ▶ Power supply $-U_B / N$
- S10 ▶ GND
- S11 ▶ 24 V DC
- S12 ▶ Input 1.1
- S13 ▶ Input 2.1
- S14 ▶ Input 2.1
- S21 ▶ Start input
- 13 ▶ Safety contact 1.1
- 14 ▶ Safety contact 1.2
- 23 ▶ Safety contact 2.1
- 24 ▶ Safety contact 2.2
- 33 ▶ Safety contact 3.1
- 34 ▶ Safety contact 3.2
- 41 ▶ Door auxiliary output 1.1
- 42 ▶ Door auxiliary output 1.2

Parameters	Value			Unit
	min.	typ.	max.	
Housing material	Plastic PA6.6			
Dimensions	114 x 99 x 22.5			mm
Weight	0.23			kg
Ambient temperature	-15	-	+ 40	°C
Degree of protection according to IEC/EN 60529	IP 20			
Mounting	35 mm DIN rail according to DIN EN 50022-35			
Type of connection	Screw terminals			
Terminals	0.14	-	2.5	mm ²
Operating voltage U _B	ESM-BA301 ESM-BA302 ESM-BA303	24 ± 10% (via isolating transformer in according to IEC/EN 61558-2-6)		AC/DC V
Rated supply frequency	50	-	60	Hz
Power consumption	approx. 7			VA
Control voltage for start button (S11)	18.6	24	26	DC V
Control cable length (with cross-section 0.75 mm ²)	-	-	1000	m
Control current for start button (S11)	approx. 60			mA
Safety contacts	3 NO contacts			
- Continuous current I _N per current path	-	-	8	A
- Cumulative current on all contacts in according to UL	-	-	15	A
- Switching voltage AC	-	-	250	AC V
- Switching voltage DC	-	-	24	DC V
- Breaking capacity AC	-	-	2,000	VA
- Breaking capacity DC (in utilization category DC-13)	-	-	48	W
- Switching current at 24 V	20	-	-	mA
- Utilization category according to IEC/EN 60947-5-1	ESM-BA301: AC-15 3A 250V / DC-13 2A 24V AC-12 8A 250V / DC-12 2A 24V ESM-BA302: AC-15 3A 250V / DC-13 3A 24V ESM-BA303: AC-12 8A 250V / DC-12 8A 50V			
- Breaking capacity in according to UL	8A 250 AC V / 2A 24 DC V			
Door auxiliary contact	1 NC contact			
- Continuous current I _N per current path	-	-	2	A
- Switching voltage AC	-	-	250	AC V
- Switching voltage DC	-	-	24	DC V
- Breaking capacity AC	-	-	500	VA
- Breaking capacity DC (in utilization category DC-13)	-	-	30	W
- Utilization category according to IEC/EN 60947-5-1	AC-15 2 A 230 V / DC-13 1.25 A 24 V AC-12 2 A 250 V / DC-12 1.25 A 24 V			
- Breaking capacity in according to UL	8A 250 AC V / 3A 24 DC V			
Contact fuses (control circuit fuse)	T 6 / F 8			A
Contact material	ESM-BA301 ESM-BA302 ESM-BA303	AgNi-10 AgSnO ₂ AgSnO ₂		
Mechanical life	1 x 10 ⁷ operating cycles			
Electrical life	1 x 10 ⁵ operating cycles			
Reverse polarity protection	On version U _B = 24 DC V			
Rated impulse withstand voltage U _{imp}	2.5			kV
Leakage path/air gap acc. to DIN VDE 0110-1:1997-04	4			kV
In compliance with	EN 60 204-1: 1998 / EN 954-1: 1996			
LEDs	2, status displays for relays K1 and K2			

Single-channel Emergency STOP connection

Dual-channel safety guard connection
see ESM-BA2.. page 11.

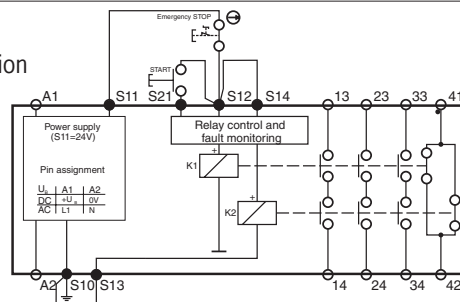

Article	Operating voltage	Safety contacts	Door auxiliary contact	Order No.
ESM-BA301	AC/DC 24 V ± 10%	3 NO contacts (redundant)	1 NC contact	085 613
ESM-BA302	AC 115 V ± 10%	3 NO contacts (redundant)	1 NC contact	087 412
ESM-BA303	AC 230 V ± 10%	3 NO contacts (redundant)	1 NC contact	087 413



- ▶ **STOP category 0**
- ▶ **Safety category 4 / IIIC**
- ▶ **Dual channel control**
- ▶ **2 positively driven safety contacts with redundancy and cyclical monitoring of the internal components**
- ▶ **Short-circuit and /or earth fault monitoring**
- ▶ **Complies with EN 60 204-1, EN 574 and EN 954-1**

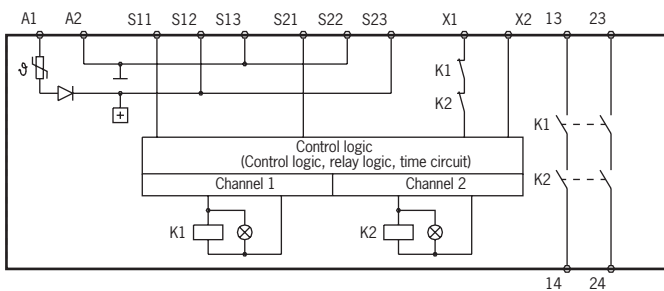
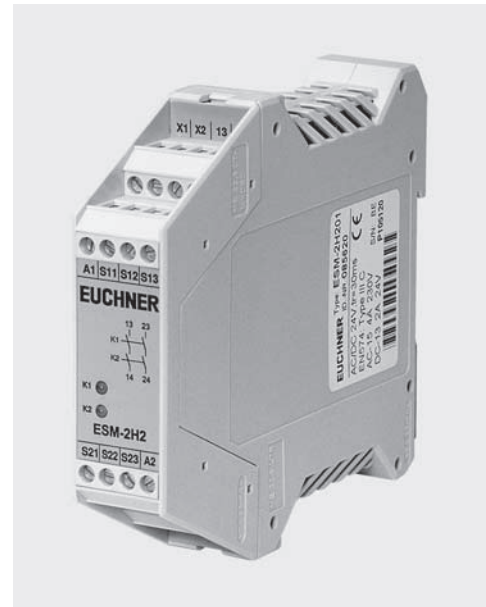
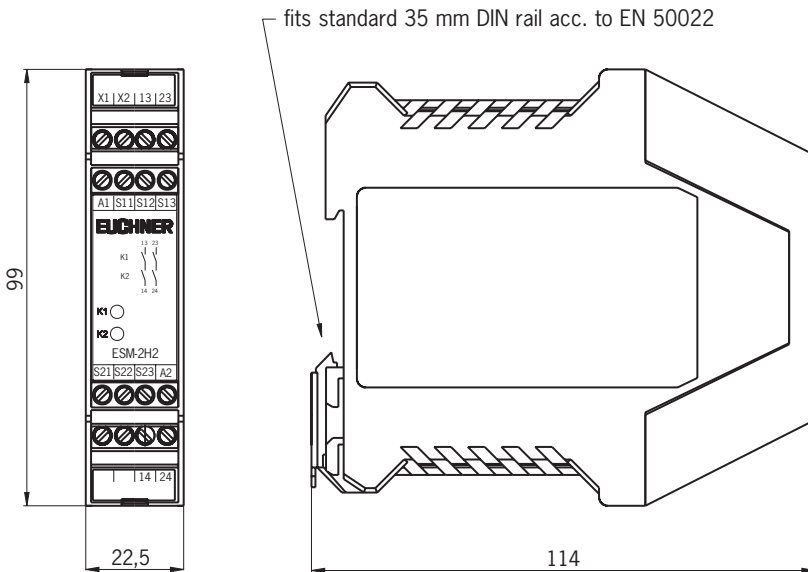

X1	X2	13	23
⊗	⊗	⊗	⊗
⊗	⊗	⊗	⊗
A1	S11	S12	S13
S21	S22	S23	A2
⊗	⊗	⊗	⊗
⊗	⊗	⊗	⊗
	14	24	

- A1 ▶ Power supply $+U_B / L$
- A2 ▶ Power supply $-U_B / N$
- S11 ▶ Input 1.1
- S12 ▶ 24 V DC
- S13 ▶ GND
- S21 ▶ Input 2.1
- S22 ▶ GND
- S23 ▶ 24 V DC
- 13 ▶ Safety contact 1.1
- 14 ▶ Safety contact 1.2
- 23 ▶ Safety contact 2.1
- 24 ▶ Safety contact 2.2
- X1 ▶ Feedback circuit 1.1
- X2 ▶ Feedback circuit 1.2

- ▶ 2 safety contacts (NO contact)
- ▶ Inputs for 2-hand control
- ▶ The 2-hand control relay must be installed in a suitable operating enclosure (control cabinet, protective housing - at least IP54).
- ▶ The 2-hand control relay is installed by clipping it to a standard 35 mm top-hat rail in accordance with EN 50022.
- ▶ All electrical inputs must be isolated from the mains by an isolating transformer (in accordance with IEC/EN 61558-2-6) or by a similar isolating method.
- ▶ The 2-hand control relay has a redundant switching design with automatic control. This means that the safety system still functions even if the component fails.
- ▶ Short-circuits and earth faults in the supply cable to the safety relay are detected.

Parameters	Value			Unit
	min.	typ.	max.	
Housing material	Plastic PA6.6			
Dimensions	114 x 99 x 22.5			mm
Weight	0.23			kg
Ambient temperature	- 15	-	+ 60	°C
Degree of protection according to IEC/EN 60529	IP 20			
Mounting	35 mm DIN rail according to DIN EN 50022-35			
Type of connection	Screw terminals			
Terminals	0.14	-	2.5	mm ²
Operating voltage U_B	24 ± 10% (via isolating transformer in according to IEC/EN 61558-2-6)			AC/DC V
Rated supply frequency	50	-	60	Hz
Power consumption AC	approx. 4			VA
Power consumption DC	approx. 2			W
Control voltage for buttons (T1 + T2)	18,6	24	26	DC V
Control cable length (with cross-section 0.75 mm ²)	-	-	1000	m
Control current for start buttons (T1 + T2)	approx. 40			mA
Synchronization time	-	-	0.5	s
Release time for the safety relay (response time)	-	-	20	ms
Safety contacts	2 NO contacts			
- Continuous current I_N per current path	-	-	6	A
- Cumulative current of all contacts	-	-	8.4	A
- Switching voltage AC	-	-	250	AC V
- Switching voltage DC	-	-	24	DC V
- Breaking capacity AC	-	-	1,500	VA
- Breaking capacity DC (in utilization category DC-13)	-	-	30	W
- Switching current at 24 V	20	-	-	mA
- Utilization category according to IEC/EN 60947-5-1	AC-15 4A 230V / DC-13 2A 24V AC-12 6A 250V (ohmic load) / DC-12 1.25A 24V (ohmic load)			
Contact fuses (control circuit fuse)	T 4 / F 6			A
Contact material	AgNi-10			
Mechanical life	1 x 10 ⁷ operating cycles			
Electrical life	1 x 10 ⁵ operating cycles			
Reverse polarity protection	at version $U_B = 24$ DC V			
Rated impulse withstand voltage U_{imp}	2.5			kV
Leakage path/air gap acc. to DIN VDE 0110-1:2003-11	4			kV
In compliance with	EN 60204-1: 1998 / EN 574: 1996 / EN 954-1: 1996			
LEDs	2, status displays for relays K1 and K2			

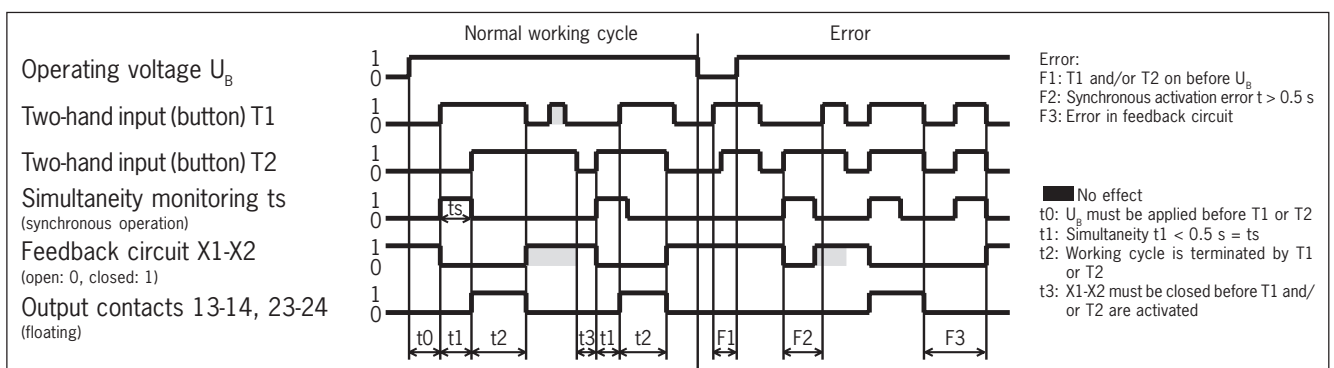
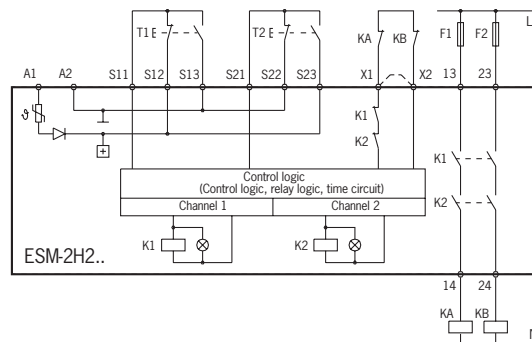

Article	Operating voltage	Safety contacts	Order No.
ESM-2H201	AC/DC 24 V ± 10%	2 NO contacts (redundant)	085 620



- ▶ STOP category 0
- ▶ Safety category 3
- ▶ Control and monitoring via safety relay
ESM-B..., SFM-..., CES-A-ABA...
- ▶ 3 positively driven safety contacts and redundancy
- ▶ Earth fault monitoring
- ▶ Complies with EN 60 204-1 and EN 954-1

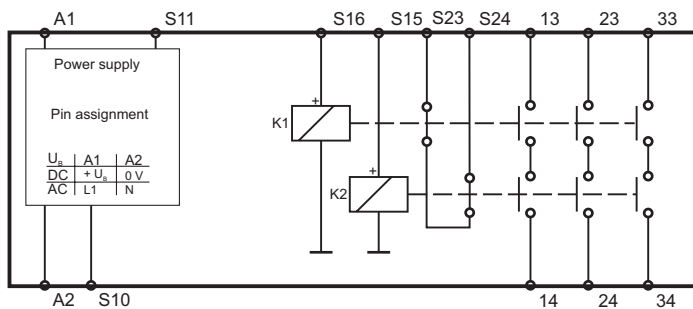
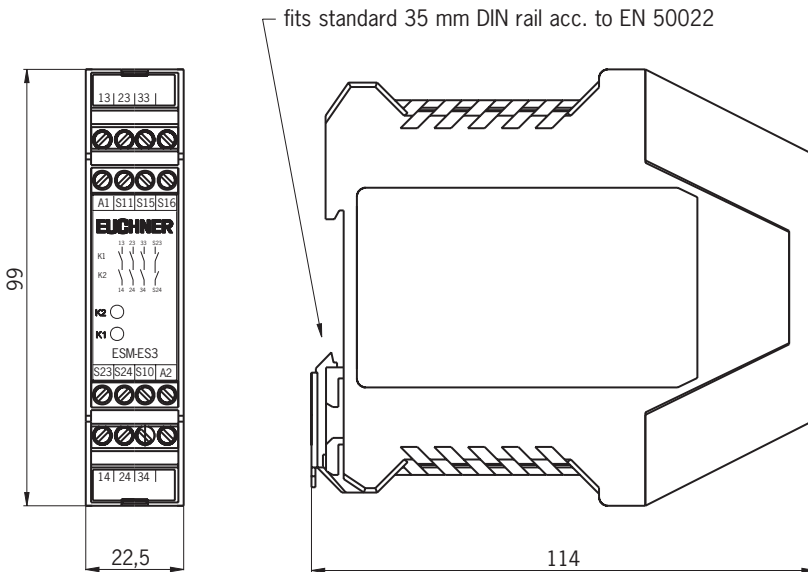

17	27	37
⊗	⊗	⊗
⊗	⊗	⊗
A1	S11	S15
S16	S10	A2
⊗	⊗	⊗
⊗	⊗	⊗
18	28	38

- A1 ▶ Power supply + U_B / L
- A2 ▶ Power supply - U_B / N
- S11 ▶ 24 V DC
- S15 ▶ Input 10.1
- S16 ▶ Input 11.1
- S23 ▶ Door error auxiliary contact 1.1
- S24 ▶ Door error auxiliary contact 1.2
- 13 ▶ Safety contact 1.1
- 14 ▶ Safety contact 1.2
- 23 ▶ Safety contact 2.1
- 24 ▶ Safety contact 2.2
- 33 ▶ Safety contact 3.1
- 34 ▶ Safety contact 3.2

- ▶ 3 safety contacts (NO contact)
- ▶ Expansion for basic safety relay ESM-B... (cascading option available), SFM..., CES-A-ABA...
- ▶ The safety expansion must be installed in a suitable operating enclosure (control cabinet, protective housing - at least IP54).
- ▶ The expansion is installed by clipping it to a standard 35 mm DIN rail in accordance with EN 50022.
- ▶ All electrical inputs must be isolated from the mains by an isolating transformer (in accordance with IEC/EN 61558 2-6) or by a similar isolating method.
- ▶ The expansion relay has a redundant switching design with automatic control. This means that the safety system is still effective even if the component fails.
- ▶ Short-circuits in the supply cable to the expansion relay are not detected.
- ▶ Earth faults in the supply cable to the expansion relay are not detected.

Parameters	Value			Unit
	min.	typ.	max.	
Housing material	Plastic PA6.6			
Dimensions	114 x 99 x 22.5			mm
Weight	0.23			kg
Ambient temperature	at $U_B = AC/DC 24 V$	- 15	+ 60	°C
	at $U_B = AC 115/230 V$	- 15	+ 40	
Degree of protection according to IEC/EN 60529	IP 20			
Mounting	35 mm DIN rail according to DIN EN 50022-35			
Type of connection	Screw terminals			
Terminals	0.14	-	2.5	mm ²
Operating voltage U_B	ESM-ES301	24 ± 10% (via isolating transformer in according to IEC/EN 61558-2-6)		AC/DC V
	ESM-ES302	115 ± 10%		
	ESM-ES303	230 ± 10%		
Rated supply frequency	50	-	60	Hz
Power consumption	approx. 4			VA
Control cable length (with cross-section 0.75 mm ²)	-	-	1000	m
Safety contacts	3 NO contacts			
- Continuous current I_N per current path	-	-	6	A
- Cumulative current of all contacts	-	-	12	A
- Cumulative current on all contacts in according to UL at 24 AC V/DC, 120 AC V, 240AC V	-	-	10.5	A
- Switching voltage AC	-	-	250	AC V
- Switching voltage DC	-	-	50	DC V
- Breaking capacity AC	-	-	1,500	VA
- Breaking capacity DC (in utilization category DC-13)	-	-	30	W
- Switching current at 24 V	20	-	-	mA
- Utilization category according to IEC/EN 60947-5-1	AC-15 4A 230V / DC-13 2A 24V AC-12 6A 250V / DC-12 1.25A 24V			
- Breaking capacity in according to UL	6A 250AC V / 2A 24 DC V per contact			
Door monitoring contact	1 NC, AC/DC 24V, 500mA only as monitoring contact for safety relay			
Contact fuses (control circuit fuse)	T 4 / F 6			A
Contact material	AgNi-10			
Mechanical life	1 x 10 ⁷ operating cycles			
Electrical life	1 x 10 ⁵ operating cycles			
Reverse polarity protection	at version $U_B = 24 DC V$			
Rated impulse withstand voltage U_{imp}	2.5			kV
Leakage path/air gap acc. to DIN VDE 0110-1:1997-04	4			kV
In compliance with	EN 60 204-1: 1998 / EN 954-1: 1996			
LEDs	2, status displays for relays K1 and K2			

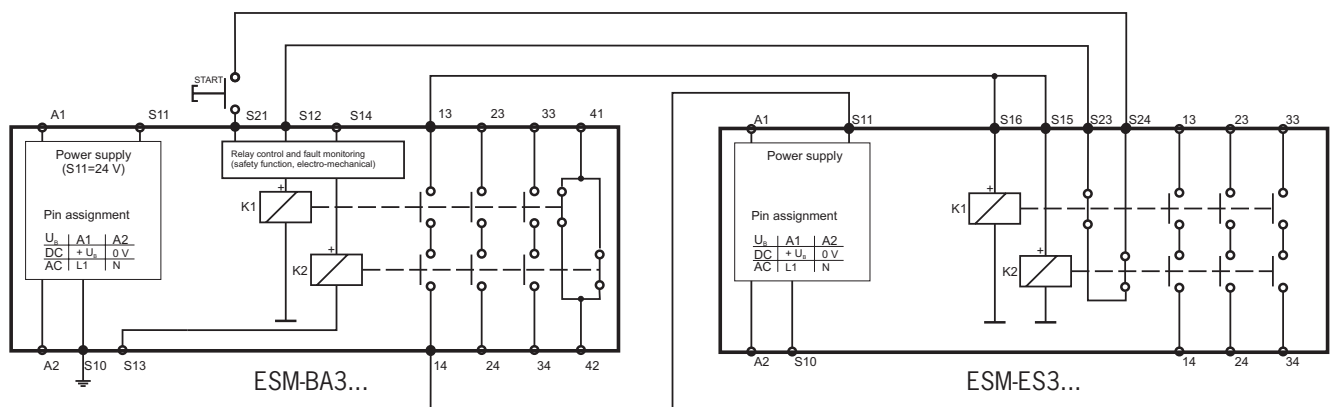

Article	Operating voltage	Safety contacts	Door auxiliary contact	Order No.
ESM-ES301	AC/DC 24 V ± 10%	3 NO contacts (redundant)	1 NC contact	085 614
ESM-ES302	AC 115 V ± 10%	3 NO contacts (redundant)	1 NC contact	085 615
ESM-ES303	AC 230 V ± 10%	3 NO contacts (redundant)	1 NC contact	085 616



- ▶ **STOP category 1**
- ▶ **Control and monitoring via safety relay**
ESM-B..., SFM-..., CES-A-ABA...
- ▶ **3 time delay (1 ... 30 s adjustable), positively driven safety contacts and redundancy**
- ▶ **Earth fault monitoring**
- ▶ **Complies with EN 60 204-1 and EN 954-1**

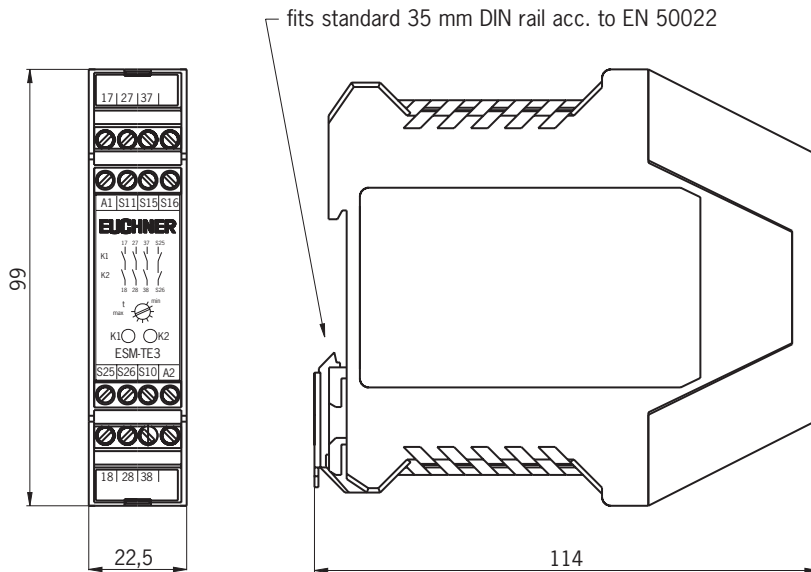

- ▶ 3 time delay safety contacts (NO contact)
- ▶ Expansion for basic safety relays ESM-B... (cascading option available), SFM..., CES-A-ABA...
- ▶ The time relay expansion must be installed in a suitable operating enclosure (control cabinet, protective housing - at least IP54).
- ▶ The expansion relay is installed by clipping it to a standard 35 mm DIN rail in accordance with EN 50022.

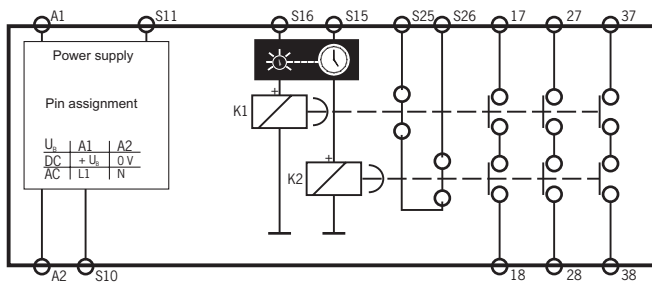

17	27	37	
⊗	⊗	⊗	
⊗	⊗	⊗	
⊗	⊗	⊗	
A1	S11	S15	S16
S25	S26	S10	A2
⊗	⊗	⊗	⊗
⊗	⊗	⊗	⊗
18	28	38	

- A1 ▶ Power supply $+U_B / L$
- A2 ▶ Power supply $-U_B / N$
- S11 ▶ 24 V DC
- S15 ▶ Input 10.1
- S16 ▶ Input 11.1
- S25 ▶ Door error auxiliary contact 1.1
- S26 ▶ Door error auxiliary contact 1.2
- 17 ▶ Safety contact 1.1
- 18 ▶ Safety contact 1.2
- 27 ▶ Safety contact 2.1
- 28 ▶ Safety contact 2.2
- 37 ▶ Safety contact 3.1
- 38 ▶ Safety contact 3.2

- ▶ All electrical inputs must be isolated from the mains by an isolating transformer (protection class III acc. to IEC/EN 61558-2-6) or by a similar isolating method.
- ▶ The expansion relay a redundant switching design with automatic control. This means that the safety system is still effective even if the component fails.
- ▶ Short-circuits in the supply cable to the expansion relay are not detected.
- ▶ Earth faults in the supply cable to the expansion relay are not detected.

Parameters	Value			Unit
	min.	typ.	max.	
Housing material	Plastic PA6.6			
Dimensions	114 x 99 x 22.5			mm
Weight	0.23			kg
Ambient temperature	at $U_B = AC/DC 24 V$	- 15	+ 60	°C
	at $U_B = AC 115/230 V$	- 15	+ 40	
Degree of protection according to IEC/EN 60 529	IP 20			
Mounting	35 mm DIN rail according to DIN EN 50022-35			
Type of connection	Screw terminals			
Terminals	0.14	-	2.5	mm ²
Operating voltage U_B	ESM-TE301	24 ± 10% (via isolating transformer in according to IEC/EN 61558-2-6)		AC/DC V
	ESM-TE302	115 ± 10%		AC V
	ESM-TE303	230 ± 10%		
Rated supply frequency	50	-	60	Hz
Power consumption	approx. 4			VA
Delay can be adjusted	1	-	30	s
Control cable length (with cross-section 0.75 mm ²)	-	-	1000	m
Safety contacts	3 NO contacts			
- Continuous current I_N per current path	-	-	6	A
- Cumulative current of all contacts at 120 V	-	-	10.5	A
at 250 V	-	-	6	A
- Cumulative current on all contacts in according to UL at 24 AC V/DC, 120 AC V, 240AC V	-	-	10,5	A
- Switching voltage AC	-	-	250	AC V
- Switching voltage DC	-	-	50	DC V
- Breaking capacity AC	-	-	1,500	VA
- Breaking capacity DC (in utilization category DC-13)	-	-	30	W
- Switching current at 24 V	20	-	-	mA
- Utilization category according to IEC/EN 60947-5-1	AC-15 4A 250V / DC-13 2A 24V AC-12 6A 250V / DC-12 1.25A 24V			
- Breaking capacity in according to UL	6A 250 AC V / 2A 24 DC V per contact			
Door monitoring contact	1 NC, AC/DC 24V, 500mA only as monitoring contact for safety relay			
Contact fuses (control circuit fuse)	T 4 / F 6			A
Contact material	AgNi-10			
Mechanical life	1 x 10 ⁷ operating cycles			
Electrical life	1 x 10 ⁵ operating cycles			
Reverse polarity protection	at version $U_B = 24 DC V$			
Rated impulse withstand voltage U_{imp}	2.5			kV
Leakage path/air gap acc. to DIN VDE 0110-1:1997-04	4			kV
In compliance with	EN 60 204-1: 1998 / EN 954-1: 1996			
LEDs	2, status displays for relays K1 and K2			

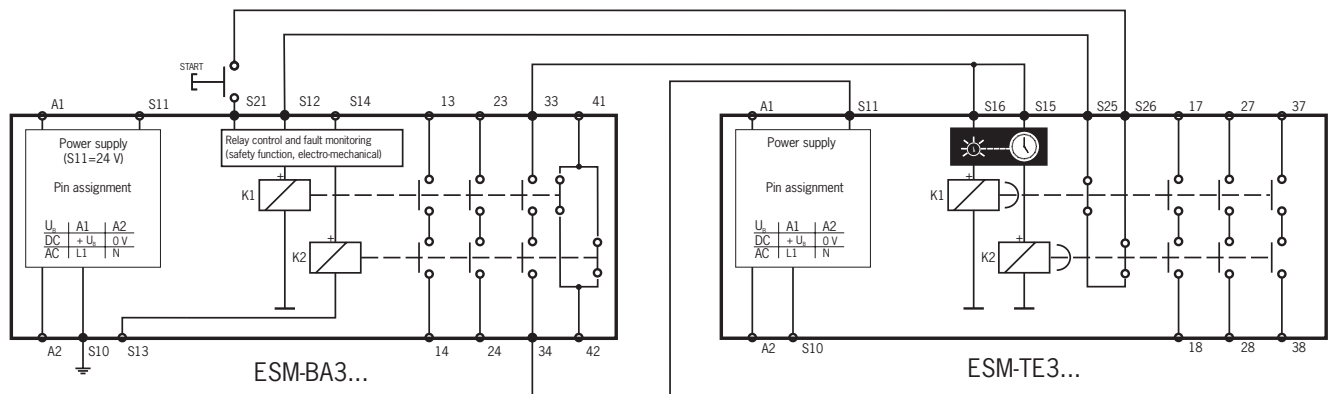

Article	Operating voltage	Safety contacts	Door auxiliary contact	Order No.
ESM-TE301	AC/DC 24 V ± 10%	3 NO contacts (redundant)	1 NC contact	085 617
ESM-TE302	AC 115 V ± 10%	3 NO contacts (redundant)	1 NC contact	085 618
ESM-TE303	AC 230 V ± 10%	3 NO contacts (redundant)	1 NC contact	085 619

Appendix

Article	Order No.	Page	Order No.	Article	Page
ESM-2H201	085 620	14	085 607	ESM-BL201	8
ESM-BA201	085 610	10	085 608	ESM-BL202	8
ESM-BA202	085 611	10	085 609	ESM-BL203	8
ESM-BA203	085 612	10	085 610	ESM-BA201	10
ESM-BA301	085 613	12	085 611	ESM-BA202	10
ESM-BA302	087 412	12	085 612	ESM-BA203	10
ESM-BA303	087 413	12	085 613	ESM-BA301	12
ESM-BL201	085 607	8	085 614	ESM-ES301	16
ESM-BL202	085 608	8	085 615	ESM-ES302	16
ESM-BL203	085 609	8	085 616	ESM-ES303	16
ESM-ES301	085 614	16	085 617	ESM-TE301	18
ESM-ES302	085 615	16	085 618	ESM-TE302	18
ESM-ES303	085 616	16	085 619	ESM-TE303	18
ESM-TE301	085 617	18	085 620	ESM-2H201	14
ESM-TE302	085 618	18	087 412	ESM-BA302	12
ESM-TE303	085 619	18	087 413	ESM-BA303	12

Representation international

Australia

Micromax Pty. Ltd.
PO Box 1238
AUS-Wollongong
NSW Australia 2500
Tel. +61 (0) 2 4271 1300
Fax +61 (0) 2 4271 8091
micromax@micromax.com.au

Austria

EUCHNER Ges. mbH
Süddruckgasse 4
A-2512 Tribuswinkel
Tel. +43 (0) 22 52 4 21 91
Fax +43 (0) 22 52 4 52 25
info@euchner.at

Benelux

EUCHNER (BENELUX) B.V.
Postbus 119
NL-3350 AC Papendrecht
Tel. +31 (0) 78 6 15 47 66
Fax +31 (0) 78 6 15 43 11
info@euchner.nl

Brazil

EUCHNER Itda.
Av. Prof. Luiz Ignacio Anhaia
Mello no. 4387
S. Lucas
São Paulo SP Brasil
CEP 03295-000
Tel. +55 (0) 11 69 18-22 00
Fax +55 (0) 11 61 01-06 13
euchner@euchner.com.br

Canada

IAC & Associates Inc.
1925 Provincial Road
Windsor, Ontario N9A 6J3
Tel. +1 (5 19) 966-3444
Fax +1 (5 19) 966-6160
sales@iacnassociates.com

China

EUCHNER Electric Shanghai Ltd.
No. 8 Workshop, Hi-Tech Zone
N. 503 MeilengDa Road
Songjiang Industrial Zone
Shanghai
Tel. +86 (0) 21 5774 7090
+86 (0) 21 5774 7091
Fax +86 (0) 21 5774 7599
info@euchner.com.cn

Knowhow I&C Co.

C-2204 Webok Times Center
No. 17 Zhongguancun Nandajie
Beijing, 100081
Tel. +86 10 8857 8899
Fax +86 10 8857 8989
info@knowhow.cn

Czech Republic

Amtek spol s.r.o.
Videňská 125
CZ-619 00 Brno
Česká republika
Tel. +420 5 47 12 55 70
Fax +420 5 47 12 55 56
amtek@amtek.cz

Denmark

Robotek EL & TEKNIK A/S
Blokken 31, Postboks 30
DK-3460 Birkerød
Tel. +45 44 84 73 60
Fax +45 44 84 41 77
info@robotek.dk

Eastern Europe

Hera Handels Ges. mbH
Hauptstraße 61
A-2391 Kaltleitgeben
Tel. +43 (0) 22 38 7 75 18
Fax +43 (0) 22 38 7 75 28
hera@telering.at

Finland

Sähkölehto Oy
Lehto & Co.
Holkkitie 14
FIN-00880 Helsinki
Tel. +358 (0) 9 774 6420
Fax +358 (0) 9 759 1071
office@sahkolehto.fi

France

EUCHNER France S.A.R.L.
Immeuble Le Colorado
ERAGNY PARC
Rue Rosa Luxembourg
Parc d'affaires des Bellevues
F-95610 ERAGNY sur OISE
Tel. +33 (0) 1 39 09 90 90
Fax +33 (0) 1 39 09 90 99
info@euchner.fr

Hong Kong

Imperial Engineers &
Equipment Co. Ltd.
Unit B 12th Floor
Cheung Lee Industrial Building
9 Cheung Lee Street
HK-Chaiwan, Hong Kong
Tel. +8 52/28 89 02 92
Fax +8 52/28 89 18 14
ieclhk@netvigator.com

Hungary

EUCHNER Ges.mBH
Magyarországi Fióktelep
H-2045 Törökbálint
Tópark Ipari park 3301/28
Feketerét u. 1.
Tel. +36/23/428 374
Fax +36/23/428 375
info@euchner.hu

India

Teknic Controlgear PVT Ltd.
703, Madhava,
Bandra Kurla Complex
Bandra East
IND-Mumbai 400051
Tel. +91-22 2659 2392
+91-22 2659 2394
Fax +91-22 2659 2391
teknic@vsnl.com

Iran

INFOCELL IRAN Co.
84, Manoucheri Ave.,
P.O. Box 81655-861, Isfahan, IRAN
Tel. +98 311 221 1358
Fax +98 311 222 6176
info@infocell-co.com

Italy

TRITECNICA S.r.l.
Viale Lazio 26
I-20135 Milano
Tel. +39 02 54 194-1
Fax +39 02 55 01 04 74
info@tritecnica.it

Japan

Solton Co. Ltd.
2-13-7, Shin-Yokohama
Kohoku-ku, Yokohama
Japan 222-0033
Tel. +81 (0) 45 4 71 77 11
Fax +81 (0) 45 4 71 77 17
sales@solton.co.jp

Korea

EUCHNER Korea Ltd.
RM 810 Daerung Technotown
#448 Gasan-Dong
Kumchon-Gu, Seoul
Tel. +82 (02) 2107 3500
Fax +82 (02) 2107 3999
sijang@euchner.co.kr

Mexico

SEPIA S.A. de C.V.
Maricopa # 10
302, Col. Napoles.
Del. Benito Juarez
MEX-03810 Mexico D:F:
Tel. +52 (5) 6822 347
Fax +52 (5) 5367 787
sepia@prodigy.net.mx

New Zealand

WAF, W. Arthur Fisher
11 Te Apunga Place
Mt. Wellington
Auckland, New Zealand
Tel. +64 (0) 9 270 0100
Fax +64 (0) 9 270 0900
chrisl@waf.co.nz

Norway

ELIS ELEKTRO AS
Jericoveien
N-1067 Oslo
Tel. +47 (22) 90 56 70
Fax +47 (22) 90 56 71
post@eliselektro.no

Poland

ELTRON
pl. Wolności 7 B
PL 50-071 Wrocław
Tel. +48 (0)71 343 97 55
Fax +48 (0)71 343 96 64
LP@eltron.pl

Portugal

PAM – Serviços Técnicos
Industriais, Lda
Rua Senhora da Alegria 188
P-4785 Alvarelhos STS
Tel. +3 51 (0) 22 98 27 518
Fax +3 51 (0) 22 98 27 519
pam@mail.telepac.pt

Singapore

SENTRONICS
Automation and Marketing Pte Ltd
Blk 3021 Ubi Avenue 2
03-169
SGP-Singapore 408897
Tel. +65/6744 8018
Fax +65/6744 1929
sentronics@pacific.net.sg

Slovenia

SMM d.o.o.
Production Systems Ltd.
Jaskova 18
SLO-2001 Maribor
Slovenia
Tel. +386 (0)2 450 23 26
Fax +386 (0)2 462 51 60
franc.kit@smm.si

Spain

EUCHNER, S.L.
Gurutegi 12 - Local 1
Polígono Belartza
E-20018 San Sebastián
Tel. +34 (9 43) 31 67 60
Fax +34 (9 43) 31 64 05
euchner@edunet.es

Sweden

Censit AB
Box 331
S-33123 Värnamo
Tel. +46 (0) 3 70 69 10 10
Fax +46 (0) 3 70 188 88
info@censit.se

Switzerland

EUCHNER AG
Ing.- und Vertriebsbüro
Großstraße 17
CH-8887 Mels/St. Gallen
Tel. +41 (0) 81 7 20 45 90
Fax +41 (0) 81 7 20 45 99
euchner.schweiz@bluewin.ch

Taiwan

Daybreak International
(Taiwan) Corp.
3 Fl., 124 Chung-Cheng Road
Shihlin
Taipei, Taiwan
Tel. +8 86 (0) 2 8 866 1231
Fax +8 86 (0) 2 8 866 1239
day111@ms23.hinet.net

Turkey

PINAR MÜHENDISLIK SAN.
ve Tic. Ltd. Sti.
Perpa Tic. Merkezi
Kat. 11, No. 1705
TR-80270 Okmeydanı/Istanbul
Tel. +90 (0) 2 12 2 20 02 77
Fax +90 (0) 2 12 2 20 13 16
pinarmuh@superonline.com

United Kingdom

EUCHNER (U.K.) Ltd.
Unit 2, Petre Drive,
GB-Sheffield, S4 7PZ
Tel. +44 (0) 1 14 2 56 01 23
Fax +44 (0) 1 14 2 42 53 33
info@euchner.co.uk

USA

EUCHNER USA Inc.
6723 Lyons St.
USA-E. Syracuse, NY 13057
Tel. +1 (3 15) 7 01-03 15
Fax +1 (3 15) 7 01-03 19
info@euchner-usa.com

